

STATE OF NEW YORK (NYS)
DEPARTMENT OF HEALTH (DOH)

eMedNY
**Prospective Drug Utilization Review/
Electronic Claims Capture and Adjudication
ProDUR/ECCA Provider Manual**

November 10, 2025
Version 2.67

TABLE OF CONTENTS

1.0	INTRODUCTION (Rev. 05/11)	1.1
2.0	GENERAL INFORMATION (Rev. 05/11)	2.1
2.1	Card Swipe (Rev. 02/19)	2.2
2.2	Response Formats (Rev. 05/11)	2.3
2.3	Electronic Claims Capture and Adjudication (ECCA) (Rev. 10/19)	2.4
2.4	Medicare and Third Party Claims (Rev. 05/14)	2.5
	Third Party and Medicare Managed Care Organizations (MCO)	2.5
	Medicare Part B	2.5
	Medicare Part D	2.6
2.5	Rebills/Adjustment Information (Rev. 05/11)	2.7
2.6	Refills Information (Rev. 06/21)	2.8
2.7	Dispensing Validation System (DVS) (Rev. 05/11)	2.9
2.8	Prior Auth Type Code and Prior Auth Number Submitted (Rev. 05/11)	2.10
2.9	Temporary Medicaid Authorizations (Rev. 05/11)	2.11
2.10	Excess Income/Spenddown Claims (Rev. 05/11)	2.12
2.11	Duplicate Claim Transactions (Rev. 05/11)	2.13
3.0	Pro-DUR Processing (Rev. 01/15)	3.1
3.1	Pro-DUR Edits	3.2
3.2	DUR Response Fields (Rev. 09/22)	3.3
	Reason For Service (Conflict Code)	3.3
	Clinical Significance	3.3
	Other Pharmacy Indicator (529-FT)	3.4
	Previous Date of Fill (530-FU)	3.5
	Quantity of Previous Fill (531-FV)	3.5
	Database Indicator (532-FW)	3.5
	Other Prescriber Indicator (533-FX)	3.5
	Conflict Code Free Text Descriptions	3.6
4.0	OVERRIDE PROCESSING (Rev. 03/24)	4.1
4.1	DUR Override (Rev. 03/24)	4.1
5.0	Pro-DUR/ECCA Input Information (Rev. 08/25)	5.1
5.1	Header Information Fields (Rev. 08/25)	5.1
5.2	Claim Information Fields (Rev. 10/25)	5.4
6.0	PRO-DUR/ECCA RESPONSE MESSAGES (Rev. 10/24)	6.1
7.0	PRO-DUR/ECCA REVERSAL/CANCEL TRANSACTIONS (Rev. 05/11)	7.1
8.0	MESSAGE CHARTS (Rev. 12/22)	8.1
	Response Message – Chart A	8.1

Additional Message – Chart B	8.2
Rejected Claim Message – Chart C.....	8.3
DUR Response – Chart D	8.4
Claim Response Message – Chart E.....	8.6
9.0 MEVS ACCEPTED CODES - TABLE 1 (Rev. 03/24).....	9.1
10.0 MEVS REJECTED CODES - TABLE 2 (Rev. 03/23)	10.1
10.1 TABLE 2 ERROR CHART (Rev. 05/11)	10.4
11.0 CO-PAYMENT CODES - TABLE 6 (Rev. 05/11)	11.1
12.0 Rx REJECTED CODES - TABLE 7 (Rev. 06/24).....	12.1
13.0 DISPENSING VALIDATION SYSTEM REASON CODES - TABLE 9 (Rev. 03/23) .	13.1
14.0 PEND REASON CODES - TABLE 10 (Rev. 11/11)	14.1
15.0 NCPDP REJECT CODES (Rev. 03/24).....	15.1
16.0 INSURANCE COVERAGE CODES - TABLE 11 (Rev. 5/11).....	16.1
17.0 EXCEPTION CODES - TABLE 12 (Rev. 12/22).....	17.1
18.0 COUNTY/DISTRICT CODES - TABLE 13 (Rev. 05/11).....	18.1
19.0 NEW YORK CITY OFFICE CODES - TABLE 14 (Rev. 01/15).....	19.1
Public Assistance	19.1
Medical Assistance.....	19.1
Special Services for Children (SSC)	19.1
Field Offices	19.2
Office of Direct Child Care Services.....	19.2
PCP Plan Codes.....	19.2

1.0 INTRODUCTION (Rev. 05/11)

The New York State Department of Health (DOH) has implemented a program that allows the pharmacy community to submit transactions in an online real-time environment that performs a Prospective Drug Utilization Review (Pro-DUR). In order to receive payment for services rendered, all pharmacies must submit their transactions through the online ProDUR system. An optional feature of the ProDUR program is the Electronic Claim Capture and Adjudication (ECCA) of claims. This program will check all prescription drugs paid by Medicaid for the member over the past 90 days and alert the pharmacists to possible medical problems associated with dispensing the new drug.

The telecommunication standards for the Pro-DUR/ECCA system are those named under the Health Insurance Portability and Accountability Act of 1996 (HIPAA). The NCPDP 5.1 and D.0 Telecommunications standard and the 1.1 and 1.2 Batch formats are supported until 01/01/2012. The NCPDP Official Release is available to NCPDP members from the following address:

National Council for Prescription Drug Programs Inc.
9240 East Raintree Drive
Scottsdale, AZ 85260
(480) 477-1000

2.0 GENERAL INFORMATION (Rev. 05/11)

In order to receive payment for services rendered, all pharmacies must submit their transactions through the online Pro-DUR program using the NCPDP transaction format. Each pharmacy must choose an access method for these transactions.

Access methods are further outlined in the Trading Partner Information Companion Guide www.eMedNY.org

An accepted transaction gives you all the necessary DUR and member eligibility information. **There is no need to do an eligibility inquiry.**

The online system is designed to allow for capture and adjudication of the electronic submission. It is each pharmacy's option as to whether the claim data should be immediately captured online by the eMedNY contractor for payment or if the actual claim will be sent by the provider using paper or electronic batch.

2.1 Card Swipe (Rev. 02/19)

Effective February 1, 2019 - eMedNY no longer supports the Verifone Vx570 Point of Sale (POS) terminal or any other devices, as they are no longer in compliance with the data privacy and security requirements and cannot be remediated.

2.2 Response Formats (Rev. 05/11)

The response for each claim will either be accepted or rejected. If the claim is rejected, reject codes will be provided to identify the nature of the problem.

Reject codes may appear in one or more of the following fields: **NCPDP Reject Codes** will be returned in the **Reject Code** (511-FB) field. **MEVS Accepted and Rejected Codes** listed in [Table 1](#) (page 9.0.1) and [Table 2](#) (page 10.0.1), **Rx Rejected codes** listed in [Table 7](#) (page 12.0.1), **DVS** codes listed in [Table 9](#) (page 14.0.1), and **Pend Reason** Codes listed in [Table 10](#) (page 15.0.1) will be returned in the **Additional Message Info** (526-FQ) field. If a claim is rejected, an **NCPDP Reject Code** will always be returned in the **Reject Code** (511-FB) field and may have a corresponding **MEVS Code** placed in the **Additional Message Info** (526-FQ) field to further clarify the error. Both fields should always be reviewed. The valid **NCPDP** and **MEVS Codes** can be found in the tables at the end of this manual.

2.3 Electronic Claims Capture and Adjudication (ECCA) (Rev. 10/19)

Captured claims will be fully edited for completeness and validity. There is a possibility that claims captured for final adjudication may be pended and subsequently denied. When a captured claim is pended, final adjudication results will appear on the remittance statement.

To submit ECCA transactions, a **Personal Identification Number (PIN)** is required. Additionally, the pharmacy must have an **Electronic Transmitter Identification Number (ETIN)** on file with eMedNY. Both of these forms may be accessed from the eMedNY website:

<http://www.emedny.org/info/ProviderEnrollment/allforms.html>

The Authorization Number field (503-F3) is not returned on the response for claims that are submitted for Capture. It is only returned for non-capture claims. If spaces are sent in the Processor Control Number field (104-A4) and a "C" is returned in the response, then the message **NO CLAIM TO FA** is returned in the Authorization Number field (503-F3).

The following types of claims cannot be submitted for ECCA:

- Durable Medical Equipment (DME) claims

- Please Note: DME does NOT include the product supply codes (1 alpha, 4 numeric) found in the MMIS Pharmacy Provider Manual in sections 4.2 and 4.3. Pharmacy DME Claims must be submitted using 837 Professional ASC X12N.

2.4 Medicare and Third Party Claims (Rev. 05/14)

Third Party and Medicare Managed Care Organizations (MCO)

A member's other insurance information (if any) is returned to you in the online response via the **Additional Message** field. If the member's other insurance covers drugs, either K, M, O or the word ALL will be returned in the Insurance Coverage Code position of the **Additional Message** Field.

For a third party or Medicare Managed Care Organization (MCO) claim to be successfully captured, the **Other Coverage Code** field and **Other Payer Amount Paid** field must be entered. Refer to the Standard Companion Guide Transaction Information for exact formatting of the COB segment. It is extremely important that the value entered in the **Other Coverage Code** field corresponds to the entry in the **Other Payer Amount Paid** field. The entry in each field must correlate to the other field and be logically correct for your claim to be accepted.

To report Patient Responsibility Amounts for Deductible, Coinsurance and Co-Pay and valid Other Patient Responsibility Amounts, refer to the COB Segment in the Standard Companion Guide, fields 351-NP (Other Payer Patient Responsibility Amount Qualifier) and field 352-NQ (Other Payer Patient Responsibility Amount). Example:

- 351-NP - Enter "01" Qualifies Deductible reported in field 352-NQ.
- 352-NQ - Enter Deductible Amount.
- 351-NP - Enter "05" Qualifies Co-Payment Amount reported in field 352-NQ.
- 352-NQ - Enter Co-Payment Amount.
- 351-NP - Enter "07" Qualifies Coinsurance Amount reported in field 352-NQ.
- 352-NQ - Enter Coinsurance Amount.

Note: The Other Payer Amount Paid Field is an optional field and should not be submitted unless the member has other drug coverage, and you have received reimbursement or been notified that the service is not covered by the other insurance company.

When submitting claims with value "3" in the (Other Coverage Code) field 308-C8, the NCPDP reject code or code(s) from the Other Payer(s) must also be entered in field 472-6E (Other Payer Reject Code).

The values for Other Coverage Code are:

- 0** = Not Specified
- 1** = No Other Coverage Identified
- 2** = Other Coverage Exists - Payment Collected
- 3** = Other Coverage Exists - This Claim Not Covered
- 4** = Other Coverage Exists - Payment Not Collected

Medicare Part B

A member's Medicare information (if known) is returned to you in the online response via the Additional Message field. If Medicare Part B covers the NDC/HCPSC code being dispensed, a claim must be submitted to Medicare first.

For a Medicare Part B primary claim to be successfully captured, the appropriate Medicare fields must be entered. Refer to the D.0 Standard Companion Guide for the formatting of the COB Segment.

Note: The Medicare fields must be submitted if Medicare has adjudicated the claim.

Medicare Part D

Prescription drugs for Medicare/Medicaid dual eligible's who have Part D coverage must be submitted to the member's Part D Prescription Drug Plan. When submitting claims for Drugs/OTCs that are excluded from Part D coverage but are covered by NYS, do not send the COB Segment.

2.5 Rebills/Adjustment Information (Rev. 05/11)

Rebills will be processed as adjustments to a previously submitted claim that was approved for payment. Rebills cannot be submitted for claims that are pending or were rejected.

Although you will need to submit all fields required for the original claim transaction, your claims will be matched to the original claim using Medicaid Provider Identification Number, Cardholder ID, Prescription Number, and Date Filled. If more than one active claim meets the criteria, the most recently submitted claim will be selected for adjustment. To adjust an older submission, submit the rebill via paper and supply the Claim Reference Number of the specific claim to adjust.

Rebill transactions can be submitted for service dates up to two years old.

While a non-ECCA claim can be adjusted, it cannot be converted to an ECCA claim.

Rebills are not allowed for original claims that generated a DVS prior approval. If a change is needed to a paid DVS claim, then the adjustment must be submitted on paper or electronic batch. To reverse the original claim, submit another original transaction with the corrected information.

2.6 Refills Information (Rev. 06/21)

Prescriptions are limited to a maximum of five refills for controlled drugs and eleven refills for non-controlled drugs. All refills for controlled drugs must be dispensed within 180 days from the date of the prescription. All refills for non-controlled drugs must be dispensed within 365 days from the date the prescription was written.

2.7 Dispensing Validation System (DVS) (Rev. 05/11)

DVS enables suppliers of prescription footwear items, specified drugs, certain medical surgical supplies and durable medical equipment to receive a prior approval number (DVS number). The DVS number will be returned in the Additional Message (526-FQ) field, and the claim will be processed for adjudication (if ECCA is requested).

Important Information Regarding DVS Transactions

- Transactions for both NDC's and HCPCS can be submitted if reimbursable under COS 0441, 0161 or 0288.
- Although multiple claim lines per transaction can be submitted, only one DVS claim line item can be submitted per transaction and the DVS line must be the first line item within the transaction.
- The Date of Service for DVS transactions must be today's date.

2.8 Prior Auth Type Code and Prior Auth Number Submitted (Rev. 05/11)

The Prior Auth Type Code (461-EU) field is a two (2) position numeric field. There are two values expected by NYSDOH for this field.

- 01** = Prior Authorization. If this value is used, then Prior Auth Number Submitted (462-EV) field must contain the eleven-digit Prior Approval number.
- 04** = Exemption from co-pay. Use to indicate the member is exempt. If this value is used, 462-EV is not submitted unless a previously obtained Prior Approval is also being reported on the claim.

2.9 Temporary Medicaid Authorizations (Rev. 05/11)

Providers must make a copy of all Temporary Medicaid Authorizations (DSS-2831A) for their records. These claims **cannot** be submitted by pharmacies through the online ProDUR/ECCA program because eligibility is not yet on file. Pharmacy providers must put the Number 4 in the Service Authorization Exception field and submit the claim directly to the eMedNY contractor via paper. If the final adjudication of the claim results in a rejected for member ineligibility, please contact the Local District Support Unit. For Upstate members call 518-474-8887; the number for New York City members is 212-417-4500.

2.10 Excess Income/Spenddown Claims (Rev. 05/11)

To properly submit a spend down claim, the **Eligibility Clarification Code** (309-C9) field must contain a value of two (2) and the **Patient Paid Amount** (433-DX) field must contain the amount paid by the member, even if that amount is zero. If the claim passes all other editing and you have elected the ECCA option, your claim will be captured and pended waiting for the eligibility file update from the local district to indicate that the spend down has been met. If the eligibility information is not updated, the claim will be denied.

2.11 Duplicate Claim Transactions (Rev. 05/11)

When an online claim transaction is sent to eMedNY, it will be matched against previously captured (approved) claims. If the transaction is determined to be an exact duplicate of a previously approved claim, eMedNY will return a “C” in the **Transaction Response Status** (112-AN) field. The remaining response fields will contain the data that was returned in the response from the original claim.

If identical data exists only in certain fields, your claim will be rejected for NCPDP Reject Code 83 “Duplicate Paid/Captured Claim” unless prior approval was obtained for one of the two conflicting transactions (meaning Prior Auth Number Submitted (462-EV) field would need to contain a PA Number on one claim, and no PA Number for the other claim.)

If the original transaction was non-ECCA and the duplicate transaction is ECCA, the transaction response will be the original non-ECCA response. No adjudication process will occur.

3.0 Pro-DUR Processing (Rev. 01/15)

A drug history profile is maintained for all members. This file contains a record for each accepted prescription or OTC item entered through the ProDUR system. Each prescription on the drug profile is assigned an expiration date. This date is calculated using the date filled plus the days supply.

All prescription and OTC transactions are compared to the member's drug profile. If the new prescription falls within the active date range (date filled plus days supply) and a conflict exists, a DUR response will be returned. ProDUR editing is not performed on compound drugs or sickroom supplies.

The DUR edits are based on the clinical database compiled by First DataBank. This information is used to administer the New York State Medicaid Pro-DUR program under the direction of the DUR Board.

Up to nine DUR related conflicts can be identified and returned for each drug submitted. Information about these conflicts is returned in the response in order of importance.

3.1 Pro-DUR Edits

The following series of edits are performed by the Pro-DUR system:

Therapeutic Duplication (TD)

The Therapeutic Duplication edit checks the therapeutic class of the new drug against the classes of the member's current, active drugs already dispensed.

Drug Overuse Alert (ER)

The Drug Overuse edit determines at the time of refill that less than 75% of the previously dispensed amount, based on the previously dispensed supply, has been used. Or the remaining days supply of the drug dispensed for the member's history claims, based on the past 90 days, has accumulated to an additional 10 days or more.

Drug-Drug Interactions (DD)

The Drug-Drug Interaction edit matches the new drug against the member's current, active drugs to identify clinically relevant interactions.

Drug-Disease Contraindications (DC)

The Drug-Disease Contraindications edit determines whether the new drug is potentially harmful to the individual's disease condition. The active drugs on drug history determine the member's disease condition(s).

Drug Pregnancy Alert (PG)

Drug Pregnancy Alert warnings are returned for females between the ages of 13 and 52 on new drugs that may be harmful to pregnant women.

Pediatric Precautions (PA)

Pediatric Precautions are returned for children under the age of eighteen (18) on new drugs that may be harmful to children.

Lactation Precautions (PG)

Lactation Precautions are returned for females between the ages of 13 and 52 on new drugs that may be harmful to nursing women or their babies.

Geriatric Precautions (PA)

Geriatric Precautions are returned for adults over the age of 60 on new drugs that may be harmful to older adults.

High Dose Alert (HD)

A High Dose Alert is returned if the dosage for the new drug exceeds the maximum dosage recommended for the member's age group.

Low Dose Alert (LD)

A Low Dose Alert is returned if the dosage for the new drug is below the minimum dosage recommended for the member's age group.

3.2 DUR Response Fields (Rev. 09/22)

The following information is returned in the response from the Pro-DUR system for each identified DUR conflict, when applicable.

Drug Conflict Code (439-E4)
Clinical Significance (528-FS)
Other Pharmacy Indicator (529-FT)
Previous Date of Fill (530-FU)
Quantity of Previous Fill (531-FV)
Database Indicator (532-FW)
Other Prescriber Indicator (533-FX)
Free Text (544-FY)
DUR Additional Text (570-NS)

Reason For Service (Conflict Code)

The Drug Conflict Code identifies the type of DUR conflict found when a new prescription is compared against the member's drug history file and demographics. Following are the values that may be returned as Drug Conflict Codes:

TD = Therapeutic Duplication
ER = Drug Overuse Alert
DD = Drug-Drug Interactions
DC = Inferred Drug Disease Precaution
PG = Drug Pregnancy Alert
PA = Drug Age Precaution
LD = Low Dose Alert
HD = High Dose Alert
NP = New Patient Processing
AD = Additional Drug Needed
PN = Prescriber Consultation

Clinical Significance

The Clinical Significance is a code that identifies the severity level and how critical the conflict. The following chart lists each drug conflict code and the clinical significance codes which may be returned for that code as well as whether they are DUR rejects or warnings.

Conflict Code	Reject/Warning	Clinical Significance	Description of Clinical Significance
TD Therapeutic Duplication	R	1	An Original Prescription that duplicates a therapy the member is already taking.
ER Drug Overuse	R	1	Prescription is a Refill and is being filled prior to 75% of the previously dispensed amount having been used.
	R	1	The remaining Days Supply of the drug dispensed for the member's history claims over the past 90 days, has accumulated to an additional 10 days or more.
DD Drug-Drug	R	1	Most significant. Documentation substantiates interaction is at least likely to occur in some patients, even though more clinical data may be needed. Action to reduce risk of adverse interaction usually required.
	W	2	Significant. Documentation substantiates interaction is at least likely to occur in some patients, even though more

Conflict Code	Reject/ Warning	Clinical Significance	Description of Clinical Significance
			clinical data may be needed. Assess risk to patient and take action as needed.
	W	3	Possibly significant. Little clinical data exists. Conservative measures are recommended because the potential for severe adverse consequences is great.
DC Drug Disease	W	1	Absolute Contraindication. Drug Therapy for the member should be changed.
	W	2	Precaution. The risk/benefit of therapy should be considered and the member's response closely monitored.
PG Pregnancy	W	D	PREGNANCY There is positive evidence of human fetal risk based on adverse reaction data from investigation or marketing experience or studies in humans, but potential benefits may warrant use of the drug in pregnant women despite potential risks.
	W	X	PREGNANCY Studies in animals or humans have demonstrated fetal abnormalities and/or there is positive evidence of human fetal risk based on adverse reaction data from investigation or marketing experience, and the risks involved in use of the drug in pregnant women clearly outweigh potential benefits.
	W	1	PREGNANCY No FDA rating but is contraindicated or not recommended; may have animal and/or human studies or pre- or post-marketing information.
	W	1	LACTATION Absolute Contraindication. The Drug should not be dispensed.
	W	2	LACTATION Precaution. Use of the Drug should be evaluated carefully.
PA Drug Age	W	1	Absolute Contraindication. Drug Therapy should be changed.
LD Low Dose	W	1	Prescribed dose is less than the minimum appropriate for the drug.
HD High Dose	W	1	Prescribed dose is greater than the maximum appropriate for the drug.

Other Pharmacy Indicator (529-FT)

The following values may be returned in the Other Pharmacy Indicator:

- 0 = Not Specified
- 1 = Your Pharmacy
- 3 = Other Pharmacy

For Early Fill edits, when the Reason for Service Code (Conflict Code) ER- (Drug Overuse Alert) is returned on the rejected claim in field 439-E4, and Other Pharmacy Indicator field (529-FT) returned values: '1' (Your Pharmacy) or '3' (Other Pharmacy), if '3' (Other Pharmacy) is returned, then the provider name, provider phone number, and provider phone number extension of the Pharmacy where the prescription was last filled will be returned in field 570-NS (DUR Additional Text) on the Response.

Note: For all other DUR Reject edits, when the conflict is caused by an "Other Pharmacy", eMedNY is not able to provide the identity of that pharmacy.

Previous Date of Fill (530-FU)

The Previous Date of Fill provides the date the conflicting drug was dispensed.

Quantity of Previous Fill (531-FV)

The Quantity of Previous Fill provides the quantity of the conflicting drug.

Database Indicator (532-FW)

The Database Indicator will always be returned with a value of 1 to indicate that First DataBank is the DUR database provider.

Other Prescriber Indicator (533-FX)

The Other Prescriber Indicator compares the Prescriber of the current prescription to the Prescriber of the conflicting drug from the member's active drug profile, and returns one of the following codes:

- 0** = Not Specified
- 1** = Same Prescriber
- 2** = Other Prescriber

For Early Fill edits, when the Reason for Service Code (Conflict Code) ER (Drug Overuse Alert) is returned on the rejected claim in field 439-E4, and Other Prescriber Indicator field (533-FX) returned values: '1' (Same Prescriber) or '2' (Other Prescriber), if '2' (Other Prescriber) is returned, then the provider name, provider phone number and provider phone number extension of the Prescriber where the prescription was last filled will be returned in field 570-NS- (DUR Additional Text) on the Response.

Note: For all other DUR Reject edits, when the conflict is caused by an "Other Prescriber", eMedNY is not able to provide the identity of that prescriber.

Conflict Code Free Text Descriptions

A Free Text message is returned for each conflict to provide additional information about the DUR condition. Following is a description of the Free Text:

Note: Bold Text in the examples below represents Free Text.

CODE FREE TEXT DESCRIPTION

TD For Clinical Significance **1**, the name, strength, dose form and day's supply of the conflicting drug from the Drug Profile.

<i>Example</i>										
TD	1	1	20020926	0000030000	1	1	PROPRANOLOL 10MG TABLET 030			

For Clinical Significance **1** the words **REJECT- DRUG OVERUSE MMDDYY**

<i>Example</i>										
ER	1	1	20080727	0000030000	1	1	REJECT - DRUG OVERUSE 081808			

Note: **MMDDYY** is the earliest date that the refill should be filled.

<i>Example</i>										
ER	1	1	20150122	0000030000	1	1	REJECT - DRUG OVERUSE (DYS) 020315			

DD Will contain the Clinical Effect Code followed by the Drug Name from the Drug Profile of the drug interacting with the new prescription being filled. The latter drug will be the new prescription drug, and the former drug will be the drug from the Drug Profile. The Clinical Effect Code will consist of one of the following values: Examples of each Clinical Effect code is included.

INF Increased effect of former drug

<i>Example</i>										
DD	2	1	20021011	0000030000	1	1	INF DIGITALIS/KALURETICS			

DEF Decreased effect of former drug

<i>Example</i>										
DD	2	1	20021012	0000030000	1	1	DEF CORTICOSTEROIDS/BARBITURAT			

INL Increased effect of latter drug

<i>Example</i>										
DD	3	1	20021003	0000030000	1	1	INL VERAPAMIL/DIGOXIN			

DEL Decreased effect of latter drug

CODE **FREE TEXT DESCRIPTION**

<i>Example</i>							
DD	2	1	20020920	0000060000	1	1	DEL NSAID/LOOP DIURETICS

ARF Adverse reaction of former drug

<i>Example</i>							
DD	2	1	20021018	0000090000	1	1	ARF THEOPHYLLINES/TICLOPIDINE

ARL Adverse reaction of latter drug

<i>Example</i>							
DD	1	1	20021014	0000050000	1	1	ARL NSAID/TRIAMTERENE

MAR Adverse reaction of both drugs

<i>Example</i>							
DD	2	1	20020920	0000090000	1	1	MAR ACE INHIBITORS/POTASS.SPAR

MXF Mixed effects of former drug

<i>Example</i>							
DD	2	1	20021018	0000015000	1	1	MXF ANTICOAGULANTS,ORAL/ANTITH

MXL Mixed effects of latter drug

<i>Example</i>							
DD	2	1	20020919	0000060000	1	1	MXL HYDANTOINS/DISOPYRAMIDE

DC The description of the drug/disease contraindication.

<i>Example</i>							
DC	1	1	20020914	0000090000	1	1	HYPERTENSION

PG For pregnancy precautions the words **PREGNANCY PRECAUTION**

<i>Example</i>							
PG	1	0	00000000	0000000000	1	0	PREGNANCY PRECAUTION

For lactation precautions the words **LACTATION PRECAUTION**

<i>Example</i>							
PG	2	0	00000000	0000000000	1	0	LACTATION PRECAUTION

CODE **FREE TEXT DESCRIPTION**

PA For pediatric precautions the word **PEDIATRIC**

<i>Example</i>								
PA	1	0	00000000	0000000000	1	0	PEDIATRIC	

For geriatric precautions the word **GERIATRIC**

<i>Example</i>								
PA	1	0	00000000	0000000000	1	0	GERIATRIC	

LD For low dose precautions the recommended minimum and maximum dosage will be shown.

<i>Example</i>								
LD	1	0	00000000	0000000000	1	0	3.000	12.000

HD For high dose precautions the recommended minimum and maximum dosage will be shown.

<i>Example</i>								
HD	1	0	00000000	0000000000	1	0	1.000	8.00

DUR ADDITIONAL TEXT- (Field 570-NS)

DUR Additional Text returned within the **DUR Response** area will provide additional information regarding the DUR Conflict if needed.

For Early Fill edits, when the Reason for Service Code (Conflict Code) ER- (Drug Overuse Alert) is returned on the rejected claim in field 439-E4, and Other Pharmacy Indicator field (529-FT) returns value: '3' (Other Pharmacy), then the provider name, provider phone number, and provider phone number extension of the Pharmacy where the prescription was last filled will be returned in field 570-NS (DUR Additional Text) on the Response. If Other Prescriber Indicator field (533-FX) returns value '2' (Other Prescriber), then the provider name, provider phone number, and provider phone number extension of the Prescriber where the prescription was last filled will be returned in this field.

Note: For all other DUR Reject edits, when the conflict is caused by an "Other Pharmacy", or "Other Prescriber", eMedNY is not able to provide the identity of that pharmacy or Prescriber.

4.0 OVERRIDE PROCESSING (Rev. 03/24)

4.1 DUR Override (Rev. 03/24)

If your claim transaction was rejected due to a DUR conflict and you intend to dispense the drug, you will need to override the conflict (if appropriate). In order to process a DUR override, the same code that was returned as the rejected code (Drug Conflict Code) must be placed in the **Reason for Service Code** (439-E4) field. The **DUR Conflict Code** being sent as the override must match the DUR Conflict Code received in the response of the original transaction. A corresponding entry must also be entered in the **Result of Service Code** (441-E6) field. The only conflict codes that are DUR rejected and reject the claim are TD (severity level 1), DD (severity level 1) and ER (severity level 1). All of the other codes being returned are warnings and allow your claim to be accepted.

Result of Service Code (441-E6) for DUR reject overrides:

- 1A = Filled as is, false positive
- 1B = Filled, Prescription as is
- 1C = Filled with Different Dose
- 1D = Filled with Different Directions
- 1E = Filled with Different Drug
- 1F = Filled with Different Quantity
- 1G = Filled with Prescriber Approval
- 1H = Brand-to-Generic Change
- 1J = Rx-to-OTC Change
- 1K = Filled with Different Dosage Form
- 2A = Prescription Not Filled
- 2B = Not Filled, Directions Clarified
- 3A = Recommendation Accepted
- 3B = Recommendation Not Accepted
- 3C = Discontinued Drug
- 3D = Regimen Changed
- 3E = Therapy Changed
- 3F = Therapy Changed – cost increased acknowledged
- 3G = Drug Therapy Unchanged
- 3H = Follow-Up/Report
- 3J = Patient Referral
- 3K = Instructions Understood
- 3M = Compliance Aid Provided
- 3N = Medication Administered
- 4A = Prescribed with acknowledgements

NOTE: The DUR Conflict Code **ER** (Drug Overuse) requires other specific Drug Conflict Codes and Submission Clarification Codes be submitted to override specific **ER** reject situations that occur.

When an early fill is needed for a client who is residing in a Long Term Care (LTC) facility, and the pharmacist is indicating that the cardholder requires a short-fill of a prescription due to a leave of absence from the Long Term Care (LTC) facility, submit the Submission Clarification Code (420-DK) of '14' (Long Term Care leave of Absence) with a non-matching 'AD' (Additional Drug) in Reason for Service Code (439-E4) along with a Result of Service Code (441-E6) from the above list to override the 'ER' conflict code.

When an early fill is needed for a client who is residing in a Long Term Care (LTC) facility, and the transaction is for a new dispensing of medication due to the patient's admission or readmission status, submit the Submission Clarification Code (420-DK) of '18' (Long Term Care Patient Admit/Readmit Indicator) with a non-matching 'NP' in Reason for Service Code (439-E4) along with a Result of Service Code (441-E6) from the above list to override the 'ER' conflict code.

DUR Override Documentation

Pharmacies must document the reason for the override. Recommended forms of documentation are:

- a) The pharmacist writes the date, reason for override and his/her signature or initials on the back of the prescription.
- b) If the software permits, comment and electronically store the reason for the override in the patient profile for the specific prescription filled.

5.0 Pro-DUR/ECCA Input Information (Rev. 08/25)

This section describes the input fields required by the Pro-DUR/ECCA system.

5.1 Header Information Fields (Rev. 08/25)

The **required header information** shown in this section is needed for each transaction request that is sent to the Pro-DUR/ECCA system.

The NCPDP field numbers are shown in parenthesis at the end of the description for each field.

Following is a description of the fields that must be submitted to the Pro-DUR/ECCA system for each transaction.

FIELD	DESCRIPTION
Alpha Characters	The two alpha characters entered in the Processor Control Number are selected by the provider and submitted to the Department of Health. (104-A4)
Bin Number	All requests must send 004740 . In most cases, this information is automatically provided by your computer software. (101-A1)
Cardholder ID Number	The Cardholder ID Number is the eight position alpha numeric Medicaid Number or the thirteen digit Access Number without the six digit ISO # prefix. Both of these values are provided on the member's benefit card. (302-C2)
Date of Birth	The Date of Birth is the date the member was born, which is provided on the member's benefit card. Format = CCYYMMDD (304-C4)
Date of Service	The Date of Service is the date the prescription was filled. The current date must be used for DVS transactions. (401-D1)
ETIN	The 3 or 4 character Electronic Transmitter Identification Number entered in the Processor Control Number assigned to the provider. (104-A4)
Patient First Name	Required when a patient has a first name. (310-CA)
Patient Gender Code	The patient gender code indicates the member's gender as follows: 1 = Male 2 = Female (305-C5)
Patient Last Name	Enter patient's last name. (311-CB)
PIN	The four digit PIN entered in the Processor Control Number is the Personal Identification Number previously selected by the provider and submitted to the Department of Health. (104-A4)

FIELD	DESCRIPTION
Place of Service	Code identifying the place where a drug or service is dispensed or administered. Refer to external code list at https://www.cms.gov/Search for Place of Service Codes . (307-C7)
Pregnancy Indicator	This code will specify whether the patient is pregnant. Valid values are: Blank = Not Specified 1 = Not pregnant 2 = Pregnant (335-2C)
Processor Control Number	Information entered in the Processor Control Number is used to indicate that you are requesting Electronic Claim Capture and Adjudication . The following fields are required by Pro-DUR/ECCA if you are requesting your claim(s) to be captured for adjudication by the eMedNY contractor. If you have been issued a four digit ETIN, you may omit the 'Y' (Read Certification Statement) Indicator in the first byte. Read Certification Statement Indicator (omit when ETIN length is 4) Two Alpha Characters PIN ETIN (104-A4)
Service Provider ID (aka Pharmacy Number)	This field must contain the ten digit NPI number. (201-B1)
Service Provider ID Qualifier	Enter 01 = National Provider Identification (NPI) (202-B2)
Software Vendor/Certification ID	Mandatory field used to identify the software source by switches and/or processors. If not available or not used between trading partners, then submit 10 spaces. (110-AK)
Transaction Code	This field identifies the type of transaction request being submitted. Acceptable codes are: B1 = Rx Billing B2 = Rx Reversal Note: B2 is used to cancel a previous transaction. Please refer to section on Reversals on page 7.0.1 B3 = Rx Rebill Note: B3 is used to adjust a previously paid claim(s). E1 = Eligibility Verification with no claim submitted N1 = Rx DUR only Note: N1 is used to supply DUR information only for purposes of updating a member's drug history file when no claim submission or reimbursement is allowed or expected. N2 = Rx DUR Reversal N3 = Rx DUR Rebill P1 = P.A. Request and Billing P2 = PA Reversal P4 = Prior Authorization Request Only S1 = Service Billing

FIELD	DESCRIPTION
	<p>S2 = Service Reversal S3 = Service Rebill</p> <p>(103-A3)</p>
Transaction Count	<p>This field identifies the number of prescriptions being submitted for a specific transaction. A number from 1 to a maximum of 4 is allowed dependent on the type of transaction.</p> <p>E1 = Eligibility (1 only) B1 = Billing submit from 1 to 4</p> <p>B2 = Reversal submit 1 per transaction for NYS. If reversing a four (4) line transaction, submit each line on a separate B2 transaction.</p> <p>B3 = Rebill submit from 1 to 4. P1 = Billing with P.A. Request submit only 1 P2 = P.A. Reversal submit only 1. P4 = P.A. Request Only submit only 1. N1 = DUR Info Report submit from 1 to 4. N2 = DUR Reversal submit 1 per transaction. N3 = DUR Rebill submit from 1 to 4. S1 = Service Billing submit from 1 to 4. S2 = Service Reversal submit only 1. S3 = Service Rebill submit from 1 to 4.</p> <p>(109-A9)</p>
Version/Release Number	<p>This identifies the NCPDP version used for your transaction and is commonly provided by your computer software.</p> <p>D0 = Telecommunication Format</p> <p>(102-A2)</p>

5.2 Claim Information Fields (Rev. 10/25)

Following is a list of information that may be required to process a claim.

FIELD	DESCRIPTION
Basis of Cost Determination	<p>The Basis of Cost Determination Code indicates the method by which (Ingredient Cost Submitted) was calculated.</p> <p>Use value 05 (Acquisition) when billing claims for Clotting Factor Products to indicate that the actual acquisition cost has been reported on the claim.</p> <p>Use value 08 (340B) when submitting claims for which a drug rebate has been received as a participant of a 340B Drug Purchasing Program. Also required:</p> <ul style="list-style-type: none"> The Submission Clarification Code Value 20- (340B Drugs)- Indicates that the drug being billed has been purchased through the 340B program. <p>Use value 15 (Free Product or No Associated Cost) when submitting Vaccine for Children (VFC) claims where the drug cost and administration fee are submitted on a single claim. This value is to be used by pharmacies that are enrolled in the Vaccine For Children (VFC) program.</p> <p>(423-DN)</p>
Compound Code	<p>The Compound Code identifies the type of prescription as follows:</p> <p>1 = Not a compound 2 = Compound - use when dispensing a compound drug.</p> <p>(406-D6)</p>
Compound Dispensing Unit Form Indicator	<p>This field is used to enter the NCPDP Standard Product billing code.</p> <p>(451-EG)</p>
Compound Dosage Form Description Code	<p>This field is used to enter the Dosage form of the complete Compound mixture.</p> <p>(450-EF)</p>
Compound Ingredient Component Count	<p>This field is used to enter the number of ingredients reported for the Compound claim. A maximum of 25 ingredients is allowed.</p> <p>(447-EC)</p>
Compound Product ID	<p>This field is used to specify the Product Identification of an ingredient used in a Compound. Enter the NDC code of the drug.</p> <p>(489-TE)</p>
Compound Product ID Qualifier	<p>Enter a code qualifying the type of product dispensed. Enter:</p> <p>03= NDC</p> <p>(488-RE)</p>
Compound Ingredient Quantity	<p>Enter the amount expressed in metric decimal units of the product included in the compound mixture. Enter the quantity for the specific ingredient reported in field 489-TE-(Compound Product ID) in this field. Enter a value of "1" in field 442-E7 (Quantity Dispensed).</p> <p>(448-ED)</p>
Compound Ingredient Drug Cost	<p>Enter the ingredient cost for the metric decimal quantity of the product included in the compound mixture indicated in "Compound</p>

FIELD	DESCRIPTION
	<p>Ingredient Quantity" field 448-ED. The usual and customary price for the entire compound claim must be entered in field 426-DQ (Usual and Customary Charged Amount).</p> <p>(449-EE)</p>
<p>Compound Ingredient Basis of Cost Determination</p>	<p>Enter the code indicating the method by which the drug cost of an ingredient used in a compound was calculated. Refer to the NCPDP D.0 External Code List for valid values.</p> <p>(490-UE)</p>
<p>Compound Type</p>	<p>This field clarifies the Type of compound. The code submitted on the claim will be checked for validity during up-front editing. Refer to the NCPDP D.0 External Code List for valid values.</p> <p>(996-G1)</p>
<p>Date Prescription Written</p>	<p>The Date the Prescription was written is entered in this field. For Refills, the Date Prescription Written cannot be over 180 days from the Date Filled for controlled drugs. For Refills, the Date Prescription Written cannot be over 365 days from the Date Filled for non-controlled drugs.</p> <p>(414-DE)</p>
<p>Days Supply</p>	<p>The Days Supply is the estimated number of days that the prescription should last. New York State does not accept a days supply greater than 366. When the prescription's directions state "take as directed" (PRN), it is strongly advised that 180 be entered as the days supply.</p> <p>(405-D5)</p>
<p>Delay Reason Code</p>	<p>This field is used to submit an Over 90 Day Reason Code on the claim. Claims which are over 90 days old from the Date of Service without a valid over 90 day reason will be denied.</p> <p>(357-NV)</p>
<p>Diagnosis Code</p>	<p>Code Identifying the diagnosis of the patient. When submitting the decimal point is always implied.</p> <p>(424-DO)</p>
<p>Diagnosis Code Count</p>	<p>Count of diagnosis occurrences.</p> <p>1 to 5 Diagnosis Codes may be sent.</p> <p>(491-VE)</p>
<p>Diagnosis Code Qualifier</p>	<p>Code qualifying the 'Diagnosis Code' being sent.</p> <p>02 = International Classification of Diseases (ICD-10).</p> <p>(492-WE)</p>
<p>Dispense As Written(DAW)/ Product Selection Code</p>	<p>Acceptable values for the Dispense As Written (DAW) code are as follows:</p> <ul style="list-style-type: none"> 0 = No product selection 1 = Substitution not allowed by prescriber 4 = Substitution allowed - Generic Drug not in stock 5 = Substitution allowed - Brand Drug dispensed as a Generic 7 = Substitution not allowed - Brand Drug mandated by Law 8 = Substitution allowed - Generic Drug not available in the Marketplace 9 = Substitution allowed by Prescriber but Plan Requests Brand <p>(408 - D8)</p>

FIELD	DESCRIPTION
Eligibility Clarification Code	<p>The Eligibility Clarification Code is used to indicate:</p> <ul style="list-style-type: none"> • An eligibility override for Excess Income/Spenddown when the member's spend down has been met but eligibility has not been updated on file. • To resubmit a previously denied claim when a Member is a Resident of an In-State Skilled Nursing Facility or Health Related Facility that includes coverage for pharmacy services. When the Member has been discharged and the records still reflect residency within the Facility, the claim may be incorrectly denied. An override may be submitted which will result in a pend status, giving the local district time to update the Member's file. • For providers to initiate a bypass from Prior Authorization (PA) when: <p>A member is a resident of a LTC facility which are either a Private Skilled Nursing Facility, Public Skilled Nursing Facility, Private Health Related Facility, or Public Health Related Facility (identified as "NH" on an eligibility response).</p> <p>AND the billing provider first obtains Medicaid eligibility <i>after</i> 90 days from the prescription date of service/fill date for claims not included in the rate.</p> <p>If the billing provider has determined that the member is a resident of a LTC facility and that the member has first obtained eligibility <i>after</i> 90 days from the prescription date of service/fill date, the provider may enter a "2" (Override) in the Eligibility Clarification Code field (309-C9), to bypass Prior Authorization (PA) requirement.</p> <p>Recognized value is: 2 = Override.</p> <p>(309-C9)</p>
Fill Number	<p>The maximum number of refills allowed is 5 for controlled drugs and 11 for non-controlled drugs. This value cannot be greater than the Number of Refills Authorized.</p> <p>(403-D3)</p>
Ingredient Cost Submitted	<p>Enter ingredient cost.</p> <p>340B providers billing Medicaid primary claims:</p> <ul style="list-style-type: none"> • Enter 340B Acquisition Cost <p>340B providers billing Medicaid secondary claim (Medicare, Commercial Insurance):</p> <ul style="list-style-type: none"> • Leave this field blank. <p>(409-D9)</p>
Number of Refills Authorized	<p>The Number of Refills Authorized is entered in this field. New York State allows a maximum of 5 refills for controlled drugs and a maximum of 11 refills for non-controlled drugs.</p> <p>(415-DF)</p>
Other Coverage Code	<p>This field is used by the pharmacy to indicate whether or not the patient has other insurance coverage or is enrolled in a Medicare Managed Care Organization (MCO). (308-C8) Valid entries NYSDOH are:</p>

FIELD	DESCRIPTION
	<p>0 = Not Specified 1 = No Other Coverage Identified 2 = Other Coverage Exists, Payment Collected – Use for Medicare Part B 3 = Other Coverage Exists, This Claim Not Covered. 4 = Other Coverage Exists, Payment Not Collected</p> <p>(308-C8)</p>
Other Payer Amount Paid	The amount qualified by the Other Payer Amount Paid Qualifier. (431-DV)
Other Payer Amount Paid Qualifier	Codes qualifying the Other Payer Amount Paid in field 431-DV. (342-HC)
Other Payer ID	ID assigned to the payer when submitting electronically. Medicare Managed Care = 13 Medicare Part B = Carrier Number Commercial Payers (TPL) = 99 (340-7C)
Other Payer Date	Payment or rejected Date of the claim being submitted for coordination of benefits. (443-E8)
Other Payer Amount Paid Count	Other payer amount paid count which is the count of other payer amount occurrences. (341-HB)
Other Payer ID Qualifier	Code qualifying the 'Other Payer ID'. (340-7C) NYSDOH will process using the following codes. 05 = Medicare Carrier No. 99 = Medicare Managed Care or Commercial Insurance (TPL) (339-6C)
Other Payer Coverage Type	Code identifying the sequence of payment responsibility for the Other Payer ID. (340-7C) (338-5C)
Other Payer Patient Responsibility Amount	Enter the Patient Responsibility as determined by the previous payer. Example: If field 351-NP = (01-Deductible), then enter Deductible Amount. (352-NQ)
Other Payer Patient Responsibility Amount Count	Enter the count of the Payer-Patient Responsibility Amount occurrences (351-NP/352-NQ) – (Max 25). (353-NR)
Other Payer Patient Responsibility Amount Qualifier	This code qualifies the Patient Responsibility amount entered in 352-NQ. The amounts used by Medicaid are as follows: 01 = Deductible Amount 04 = Amount reported from previous payer as Exceeding Periodic Benefit Maximum. 05 = Copay Amount 06 = Patient Pay Amount

FIELD	DESCRIPTION
	<p>07 = Coinsurance Amount. 09 = Health Plan Assistance Amount 12 = Coverage Gap Amount</p> <p>(351-NP)</p>
Other Payer Reject Count	<p>Number of third party rejected codes.</p> <p>(471-5E)</p>
Other Payer Reject Code	<p>Enter the rejection code that was received from the primary payer.</p> <p>NYS Medicaid will not accept a combination of Other Coverage Code of '3' in NCPDP field 308-C8 (Other Coverage Code) with ANY reject code in field 472-6E when another third party is responsible for payment. The provider should work with the primary insurance to resolve the rejection prior to resubmission, which may require obtaining prior authorization. Your claim will be rejected with Pre-Adjudication edits NCPDP Reject Codes '6E' (M/I Other Payer Reject Code)/'13' (M/I Other Coverage Code).</p> <p>However, since many Third Party Payers do not cover Over the Counter (OTC) medications (Rx Type 07), system editing will allow OTC medications to process if NCPDP field 472-6E- (Other Payer Reject Code) contains value 'MR' (Product Not on Formulary) or '70' (Product/Service Not Covered) and Other Coverage Code is '3', and the product is on the list of reimbursable drugs for NY Medicaid.</p> <p>Note: For clarification of Rx Types, visit eMedNY.org, Formulary File Search Page.</p> <p>(472-6E)</p>
Patient First Name	<p>Required when the patient has a first name.</p> <p>(310-CA)</p>
Patient Last Name	<p>Enter the Patient's last name.</p> <p>(311-CB)</p>
Patient Paid Amount Submitted	<p>This field is used by the pharmacy to enter the dollar amount collected toward satisfying the member's spend down requirement.</p> <p>Note: If the spend down was previously met but the eligibility file has not yet been updated, enter zeroes in this field. Refer to Section 2.10 on page 2.10.1 for additional information on this field.</p> <p>(433-DX)</p>
Place of Service	<p>Code identifying the Place where a drug or service is dispensed or administered. Enter Place of Service.</p> <p>Note: Refer to https://www.cms.gov/ Search for Place of Service Codes.</p> <p>(307-C7)</p>
Primary Care Provider ID	<p>Enter the NPI of the primary care provider the member is restricted to.</p> <p>(421-DL)</p>
Primary Care Provider ID Qualifier	<p>Enter 01 (NPI)</p> <p>(468-2E)</p>
Prior Authorization Number Submitted	<p>Enter the 11 digit Prior Authorization Number when applicable.</p> <p>(462-EV)</p>

FIELD	DESCRIPTION
Prior Authorization Type Code	This code will specify co-pay exemption or clarify a Prior Authorization request or submission. Valid values are: 00 = Not specified 01 = Prior Authorization 04 = Exemption from co-pay (461-EU)
Prescriber ID	Enter the NPI of the Prescriber. (411-DB)
Prescriber ID Qualifier	Enter 01 (NPI) (466-EZ)
Prescription Origin Code	Code indicating the origin of the prescription. (419-DJ)
Prescription/Service Reference Number	The Prescription Number assigned by the pharmacy. (402-D2)
Prescription/Service Reference Number Qualifier	Indicates the type of billing submitted. Valid Values are: 1 = Rx Billing for B1, B2, B3 2 = Service Billing for S1, S2, S3 (455-EM)
Procedure Code Modifier	The Procedure code modifier is reported in this field. Up to four occurrences are allowed. (459-ER)
Procedure Modifier Code Count	Enter the number of Procedure Modifiers reported. (458-SE)
Product/Service ID Number	The NDC Number, the CPT4 code, CPT5 code or the HCPCS code being billed. For compounds, enter 0. (407-D7)
Product/Service ID Qualifier	Enter the appropriate Product/Service ID Qualifier. When billing for a compound, enter '00' 00 = Not Specified 03 = NDC 07 = CPT4 08 = CPT5 09 = HCPCS (436-E1)
Provider ID (Pharmacy)	Enter the NPI of the dispensing pharmacist. (444-E9)
Provider ID Qualifier (Pharmacy)	Enter 05 = National Provider Identifier (NPI). (465-EY)
DUR/PPS Code Counter	Enter the DUR number occurrence (up to 9). (473-7E)
Reason for Service Code	When a claim is denied due to one or more of the following DUR Conflict Codes, each must have an appropriate DUR reject override for the claim to pay.

FIELD	DESCRIPTION
	<p> TD = Therapeutic Duplication DD = Drug to Drug Interaction NP = New Patient Processing AD = Additional Drug Needed PN = Prescriber Consultation </p> <p>(439-E4)</p>
Result of Service Code	<p>The DUR Outcome Code is used to indicate the action taken by the pharmacist and is required for a DUR override.</p> <p>(441-E6)</p>
Route of Administration	<p>This is an override to the “default” route referenced for the product. For a multi-ingredient compound, it is the route of the complete compound mixture. Refer to the NCPDP D.0 External Code List for valid values.</p> <p>Required when billing for compound drugs:</p> <ul style="list-style-type: none"> • SNOMED CT Route of Administration subset <p>Valid values:</p> <ul style="list-style-type: none"> • 6064005 - Topical • 9942002 - Transluminal • 10547007 - Otic • 12130007 - Intra-articular route • 16857009 - Vaginal • 17751009 - External Route • 26643006 - Oral • 26643008 - Mouth/Throat • 34206005 - Subcutaneous • 37161004 - Rectal • 37839007 - Sublingual • 38239002 - Intraperitoneal route • 45890007 - Transdermal • 46713006 - Nasal • 47056001 - Irrigation • 47625008 - Intravenous • 54471007 - Buccal route • 54485002 - Ophthalmic • 58100008 - Intra-arterial • 59593002 - Intradermal route • 72607000 - Intrathecal • 78421000 - Intramuscular • 89947002 - Intraepithelial route • 90028008 - Urethral route • 112239003 - Inhalation • 127490009 - Gastrostomy • 127491008 - Jejunostomy route • 127492001 - Nasogastric route • 127493006 - Percutaneous gastrostomy (button) • 372449004 - Dental • 372454008 - Gastroenteral • 372457001 - Gingival route • 372461007 - Intracavernous route • 372464004 - Intradermal route • 372467006 - Intralymphatic route • 372468001 - Intraocular route • 372469009 - Intrapleural route • 372471009 - Intravesical route

FIELD	DESCRIPTION
	<ul style="list-style-type: none"> • 372472002 - Ocular route • 372473007 - Oromucosal • 372474001 - Periarticular route • 385218009 - Injection • 404815008 - Transmucosal route • 404816009 - IV Push • 404817000 - IV Piggyback • 417950001 - Intrathoracic route • 417985001 - Enteral route • 418091004 - Intratympanic route • 418114005 - IV Central • 418136008 - Gastro-intestinal stoma route • 418162004 - Colostomy route • 418331006 - Intra-cartilaginous route • 418401004 - Intravitreal route • 418441008 - Orogastic route • 418511008 - Transurethral route • 418608002 - Intracorneal route • 418664002 - Oropharyngeal route • 418743005 - Fistula route • 419464001 - Iontophoresis route • 419874009 - Submucosal route • 419894000 - Surgical cavity route • 419954003 - Ileostomy route • 419993007 - Intravenous route • 420163009 - Esophagostomy route • 420254004 - Body cavity route • 421031008 - Oromucosal route-other • 421032001 - Peritoneal Dialysis • 421503006 - Hemodialysis • 424109004 - Injection • 424494006 - Infusion • C444364 - By infusion <p>(995-E2)</p>
Scheduled Prescription ID Number	<p>NYSDOH requires the Prescription Pad Serial Number of the Official New York State Prescription blank / form in order to process a claim. Some valid Prescriptions can be dispensed when not written on Official Prescription Forms. For these specific situations, in lieu of the Prescription Serial Number, use the following values:</p> <ul style="list-style-type: none"> • Prescriptions written by Out of State prescribers or by practitioners within a federal institution (e.g., US Department of Veterans Affairs) or Indian Reservation use: <u>ZZZZZZZZ</u> • Electronic - Prescriptions obtained via SCRIPT or HL7 standard transactions, or electronically within closed systems, use: EEEEEEEE • Telephone Prescriptions or Pharmacy dispensing when applicable, use: 99999999 • Faxed Non-Controlled Prescriptions for nursing home patients, use: NNNNNNNN • Telephone or faxed fiscal orders for supplies, use: SSSSSSSS

FIELD	DESCRIPTION
	<ul style="list-style-type: none"> For any situation where a new Rx number needs to be created from an existing valid prescription such as traditional transfers, intra-chain transfers, file buys, software upgrades/migration, and any lawful reason necessary to give it a new number, use: TTTTTTTT (454-EK)
Submission Clarification Code	<p>The Submission Clarification Code is used for specific DUR overrides and for other clarifications.</p> <p>05 = Therapy Change – Required when: or 06 = Starter Dose - Required When: or 07 = Medically Necessary – Required When:</p> <ul style="list-style-type: none"> to override Polypharmacy Conflicts with prior service and Reason for Service PN (Prescriber Consultation) DUR Reject , following prescriber consultation; submit Reason for Service PN with Submission Clarification Code. <p>Medically Necessary - use to indicate the service is provided as a result of Immediate Urgent Care or Emergency. Required when:</p> <ul style="list-style-type: none"> Note: override combination (AD/07) will only be made valid for use during specific authorized events or states of Emergency when announced and directed by NYSDOH. <p>08 = Process Compound for Approved Ingredients. Required When:</p> <ul style="list-style-type: none"> Code “08” will be recognized as an override to any ingredient not payable by NYS. This will allow only payable ingredients to be paid without denying the claim <p>10 = Meets Plan Limitations – The pharmacy certifies that the transaction is in compliance with the program’s policies and rules that are specific to the particular product being billed. Required when:</p> <ul style="list-style-type: none"> instructed by the NYSDOH <p>14 = Long Term Care Leave of Absence – when an early fill is needed for a client who is residing in a Long Term Care (LTC) facility, and the pharmacist is indicating that the cardholder requires short fill of a prescription due to a leave of absence from the Long Term Care facility. Required when:</p> <ul style="list-style-type: none"> The Reason for Service AD (Additional Drug) and Result of Service Code to bypass early fill due to Long Term Care Leave of Absence. <p>18 = Long Term Care Patient Admit/Readmit indicator- when an early fill is needed for a client who is residing in a Long Term Care (LTC) facility, and the transaction is for a new dispensing of medication due to the patient’s admission or readmission status. Required when:</p> <ul style="list-style-type: none"> The Reason for Service NP (New Patient Processing) and Result of Service Code to bypass early fill due to Long Term Care Admit/Readmit Indicator. <p>20 = (340B Drugs) – Indicates that the drug being billed has been purchased through the 340B program. Required when:</p> <ul style="list-style-type: none"> the Basis of Cost Determination 08 (340B) is being submitted on a claim for which a drug rebate has been

FIELD	DESCRIPTION
	<p>received as a participant of a 340B drug purchasing program.</p> <p>42 = Prescriber ID Submitted is valid and prescribing requirements have been validated - Required when:</p> <ul style="list-style-type: none"> • State of Emergency prescription declarations allow the pharmacy/pharmacist to authorize a prescription refill when the prescriber cannot be contacted. <p>The following codes are used by Long Term Care (LTC) pharmacies to indicate when a claim is being dispensed with a short days supply of medication – Required When:</p> <ul style="list-style-type: none"> • 06 = Starter Dose • 10 = MT PLN LMT • 14 = Short FILL LOA from LTC • 17 = Remainder AFT Emergency Kit • 21 = 14 Days or Less • 22 = 7 Day Supply • 23 = 4 Day Supply • 24 = 3 Day Supply • 25 = 2 Day Supply • 26 = 1 Day Supply • 27 = 4 Then 3 Day Supply • 28 = 2 Then 2 Then 3 Day Supply • 29 = Daily and 3 Day Weekend • 30 = Per Shift Dispensing • 31 = Per Med Pass Dispensing • 32 = PRN On Demand • 33 = 7 Days or Less • 34 = 14 Day Dispensing • 35 = 8 – 14 Days Dispensing <p>(420-DK)</p>
Submission Clarification Code Count	<p>This field is used for reporting the Number of occurrences (up to 3) of the Submission Clarification Code field (420-DK).</p> <p>(354-NX)</p>
Quantity Dispensed	<p>The Quantity Dispensed is the total number of Metric Units dispensed for the prescription. Except in the case of a compounded product when the quantity dispensed value must be “1”.</p> <p>(442-E7)</p>
Usual and Customary Charge	<p>The Usual and Customary Charge is used to enter the amount charged for the prescription.</p> <p>(426-DQ)</p>

6.0 PRO-DUR/ECCA RESPONSE MESSAGES (Rev. 10/24)

The information that is received from the NYS DOH Pro-DUR/ECCA system will vary depending upon whether the claim has been accepted or rejected. A separate response will be received for each claim submitted. For example, if three claims are submitted at a time, three responses will be returned from Pro-DUR/ECCA.

The NCPDP field numbers are shown in parenthesis at the end of the description for each field.

Following is a description of the information returned from Pro-DUR/ECCA for each request that is sent.

FIELD	DESCRIPTION
Header Response Status	<p>An A (Accepted) will be returned if the information in the transmission is valid. An R (Rejected) will be returned if the information in the transmission is invalid. Further clarification of the reject will be indicated by NCPDP Reject codes and in the Message Area.</p> <p>Note: When an R is returned in the Header Response Status, all of the claims submitted on this request transaction will be rejected.</p> <p>(501-F1)</p>

Following is a description of the information that will be returned from Pro-DUR/ECCA for each claim sent.

Note: The following field descriptions are in alphabetical order and not necessarily the order in which they appear in the response.

FIELD	DESCRIPTION
Additional Message Info	<p>The Additional message area, in the NCPDP format, is used to return additional MEVS information about your request transaction.</p> <p>The following information is returned for accepted or pending transactions:</p> <ul style="list-style-type: none"> • MEVS Response Code (See Table 1) • Utilization Threshold Code (See Note below) • Maximum Per Unit Price • Co-Payment Code (See Table 6) • Co-Payment Met Date • DVS Reason Code (See Table 9) • Medicare Coverage Code • Medicare Identifier • First Insurance Carrier Code • First Insurance Coverage Codes (See Table 11) • Second Insurance Carrier Code • Second Insurance Coverage Codes (See Table 11) • Indication of Additional Coverage • Exception Codes (See Table 12) • DVS Number <p>(526-FQ)</p> <p>Please refer to Chart B for an example of the Additional Message.</p> <p>The following information is returned for rejected claims:</p> <ul style="list-style-type: none"> • MEVS Response Code (See Table 2) • Rx Rejected Code (See Table 7) • Utilization Threshold Code (See Note below)

FIELD	DESCRIPTION
	<ul style="list-style-type: none"> • DVS Reason Code (See Table 9) <p>Please refer to Chart C for an example of the Message.</p> <p>*Note: Effective July 1, 2022, revisions to current law for the Utilization Threshold Program has changed the UT Program to a post payment review process. Your claim will not be denied. The codes being returned in this field will be a place holder.</p> <p>(526-FQ)</p>
Amount of Copay	<p>The amount of co-pay due for the entered NDC or HCPCS (NY Product Supply Code) will be returned if the member has not met their co-pay and is not exempt.</p> <p>(518-FI)</p>
Anniversary Month	<p>The Anniversary Month found in the Message Field (504-F4) is the beginning month of the benefit year under the Utilization Threshold program.</p>
Approved Message Code	<p>NYSDOH may return if applicable, a Message Code on an approved claim/service, communicating the need for an additional follow-up.</p> <p>005 (Claim paid under the plan's transition benefit period, otherwise claim would have rejected as prior authorization required).</p> <p>Note: The code '005' is in reference to the Pharmacy Carve-out, where Medicaid members enrolled in Mainstream (MC) Plans, Health and Recovery Plans (HARPs), and HIV- Special Needs Plans (SNPs) will receive their Pharmacy benefits through the Medicaid FFS Pharmacy Program instead of their Medicaid MC Plan. The FY 2022 Enacted Budget delays the transition of the Medicaid pharmacy benefit until April 1, 2023. Therefore, the fields 547-5F, 548-6F and valid value code "005" will not be returned on the NCPDP Response until the Pharmacy Carve-out transition takes place.</p> <p>(548-6F)</p>
Approved Message Code Count	<p>Maximum of 5. Required if Approved Message Code is used.</p> <p>See "Note" details documented in field 548-6F regarding when this field will be returned.</p> <p>(547-5F)</p>
Authorization Number	<p>The Authorization Number field (503-F3) is not returned on the response for claims that are submitted for capture. It is only returned for non-capture claims. If spaces are sent in the Processor Control Number field (104-A4) and a "C" is returned in the response, then the message NO CLAIM TO FA is returned in the Authorization Number Field.</p> <p>(503-F3)</p>
Basis of Reimbursement Determination	<p>Code identifying how the reimbursement amount was calculated for Ingredient Cost Paid. Valid Values and NYSDOH pricing source in bold:</p> <ul style="list-style-type: none"> • 0 - Not Specified – (Priced using Manual Price) • 3 - Ingredient Cost Reduced to AWP Less X% Pricing- (Priced using AWP) • 4 - Usual & Customary Paid as Submitted- (Priced using Total Charge Amount) • 5 - Lower of U&C- (Calculated price by FMAC, then SMAC, Otherwise E)

FIELD	DESCRIPTION
	<ul style="list-style-type: none"> • 12 - 340B/Disproportionate Share/PHSP –(Priced 340B) • 13 - WAC (Wholesale Acquisition Cost)- (Priced using WAC) • 14 - Other Payer- Patient Responsibility Amount- (Priced using Medicare or Other Insurance Requested Amount) • 17 - Special Patient Reimbursement- (Priced using PA Excess Amount) • 19 - State Fee Schedule (SFS) Reimbursement- (Priced using SMAC) • 20 - National Average Drug Acquisition Cost (NADAC) - (Priced using NADACB or NADACG) • 22 - Basis of Cost Free Product – (Priced using VFC Vaccine Pricing) • 24 - Federal Upper Limit (FUL)- (Priced using FMAC) • 25 - Nominal Pricing – (Priced using non-VFC Vaccine Pricing) • 26 - Federal Supply Schedule – (Priced using Procedure Price) <p>Note: The Basis of Reimbursement Determination will be set to '0' (Not Specified) for compound claims.</p> <p>(522-FM)</p>
Category of Assistance	Category of Assistance Code returned within the Message Field (504-F4): S = SSI * = No valid category of assistance is available
Clinical Significance	Clinical Significance returned within the DUR Response area indicates how critical the conflict is. This value reflects the severity level assigned to a contraindication. Refer to DUR Processing Section for a list of clinical significance codes and their meanings. (528-FS)
Co-Payment Code	The Co-Payment Code returned within the Additional Message Info (526-FQ) provides the status of co-payment for this claim.
Co-Payment Met Date	The Co-Payment Met Date returned within the Additional Message Info (526-FQ) identifies the date the member has met this year's co-payment requirement.
County Code	The two-digit code for the county of fiscal responsibility for the member is provided within the Message Field (504-F4). (See Table 13)
Database Indicator	The Database Indicator returned within the DUR Response area is always 1 to indicate that First DataBank is the source of the DUR database. (532-FW)
Dispensing Fee Paid	The Dispensing Fee Paid will be returned in the Response Pricing Segment. <i>Note: The dispensing fee amount will be returned on COB claims and drugs which reimburse at U&C charge amount. This does not mean it was paid in these instances, just that it was utilized in the overall reimbursement logic calculation. The total paid amount will not include the dispensing fee amount for these claim types identified above.</i> (507-F7)
Dispensing Validation	The eleven digit DVS Number (prior approval) will be returned in the Additional Message Info (526-FQ) if the DVS transaction is

FIELD	DESCRIPTION
System Number	accepted. If you did not submit the claim for ECCA and are billing manually, this number must be put on your claim form.
Dispensing Validation System Reason Code	The three-digit code indicating either the accepted or rejected status of the DVS request is returned within the Additional Message Info (526-FQ).
DUR Additional Text	<p>DUR Additional Text returned within the DUR Response area will provide additional information regarding the DUR Conflict if needed:</p> <ul style="list-style-type: none"> For Early Fill edits, when the Reason for Service Code (Conflict Code) ER- (Drug Overuse Alert) is returned on the rejected claim in field 439-E4, and Other Pharmacy Indicator field (529-FT) returns value: "3"- (Other Pharmacy), then the provider name, provider phone number, and provider phone number extension of the Pharmacy where the prescription was last filled will be returned in field 570-NS- (DUR Additional Text) on the Response. If Other Prescriber Indicator field (533-FX) returns value "2"- (Other Prescriber), then the provider name, provider phone number and provider phone number extension of the Prescriber where the prescription was last filled will be returned in this field. <p>Note: For all other DUR Reject edits, when the conflict is caused by an "Other Pharmacy", or "Other Prescriber", eMedNY is not able to provide the identity of that pharmacy or Prescriber.</p> <p>(570-NS)</p>
DUR/PPS Response Code Counter	The DUR number occurrence (up to 9) is returned. (567-J6)
Exception Codes	Up to four Exception Codes may be returned within the Additional Message Info (526-FQ). (See Table 12)
Free Text	The Free Text returned within the DUR Response area contains information to assist the pharmacist in further identifying the DUR conflict. Please refer to the DUR Processing section. (544-FY)
Medicare Identifier	The Medicare Identifier will be returned within the Additional Message Info (526- FQ).
Indication of Additional Coverage	A ZZ returned within Additional Message Info (526-FQ) indicates that the member has more than two insurance carriers. Call 1-800-343-9000 to obtain complete information.
First Insurance Carrier Codes	The First Insurance Carrier Code is the first code found in the Medicaid files and should not be interpreted as primary. This is returned within the Additional Message Info (526-FQ).
First Insurance Coverage Codes	The First Insurance Coverage Codes are returned within the Additional Message Info (526-FQ). These indicate the scope of benefits. (See Table 11)
Second Insurance Carrier Codes	The Second Insurance Carrier Code is the second code found in the Medicaid files and should not be interpreted as secondary. This is returned within the Additional Message Info (526-FQ).
Second Insurance Coverage Codes	The Second Insurance Coverage Codes are returned within the Additional Message Info (526-FQ). These indicate the scope of benefits. (See Table 11)
Maximum Per Unit Price	The Maximum Per Unit Price returned within the Additional Message Info (526-FQ) is the per unit amount on the Drug File.

FIELD	DESCRIPTION
	The price is the maximum reimbursable unit price. The dollar amount returned to you in your response does not indicate the amount of payment you will receive.
Medicaid Number	The Member's Identification Number is provided within the Message Field (504-F4).
Medicare Coverage	<p>The Medicare Coverage code is returned within the Additional Message Info (526-FQ) and indicates the type of Medicare coverage.</p> <ul style="list-style-type: none"> A = Member has only Part A Medicare coverage. B = Member has only Part B Medicare coverage. C = Member has both Part A and Part B Medicare coverage. Q = Member has Part A and Part B Medicare coverage and is a Qualified Medicare Beneficiary (QMB). T = Member is a QMB only. D = Member has only Part D Medicare coverage. E = Member has both Part A and Part D Medicare coverage. F = Member has both Part B and Part D Medicare coverage. G = Member has Part A and Part B and Part D Medicare coverage. H = Member has Part A and Part B and Part D Medicare coverage and is a QMB.
Message field	<p>A Message field is used to provide eligibility information.</p> <p>The following information is returned for accepted claims (when Claim Response = C):</p> <ul style="list-style-type: none"> • Medicaid Number • County Code (See Table 13) • Anniversary Month • Patient Gender Code • Year of Birth • Category of Assistance • Re-certification Month • Office Number (See Table 14) • Service Date <p>Please refer to Chart A for an example of the Message. (504-F4)</p>
MEVS Response Code	The MEVS Code for a member eligible transaction is returned within the Additional Message Info (526-FQ). Refer to Table 1 for a list of values and meanings.
MEVS Rejected Code	<p>The MEVS Rejected Code for a member ineligible transaction is returned within the Additional Message Info (526-FQ) and indicates the MEVS error for rejected transactions.</p> <p>Refer to Table 2 for a list of values and meanings.</p>
Office Number	<p>The Office Number returned within the Message field (504-F4) represents the New York City office code. Table 14</p> <p>The Office Code 'H78' is returned for members who have coverage through the NY Health Benefit Exchange. The phone number for inquiries pertaining to eligibility issues for members enrolled through the NY Health Benefit Exchange is 855-355-5777.</p>
Other Pharmacy Indicator	The Other Pharmacy Indicator returned within the DUR Response area indicates the source of the previous prescription that forms the basis for the conflict with the present prescription. The following values may be returned.

FIELD	DESCRIPTION
	<p> 0 = Not Specified 1 = Your Pharmacy 3 = Other Pharmacy </p> <p>For Early Fill edits, when the Reason for Service Code (Conflict Code) ER- (Drug Overuse Alert) is returned on the rejected claim in field 439-E4, and Other Pharmacy Indicator field (529-FT) returns value '3' (Other Pharmacy), then the provider name, provider phone number, and provider phone number extension of the Pharmacy where the prescription was last filled will be returned in field 570-NS- (DUR Additional Text) on the Response.</p> <p>Note: For all other DUR Reject edits, when the conflict is caused by an "Other Pharmacy", eMedNY is not able to provide the identity of that pharmacy.</p> <p>(529-FT)</p>
Other Prescriber Indicator	<p>The Other Prescriber Indicator returned within the DUR Response area compares the Prescriber of the current prescription to the Prescriber of the previously filled conflicting prescription. The following values may be returned:</p> <p> 0 = Not Specified 1 = Same Prescriber 2 = Other Prescriber </p> <p>For Early Fill edits, when the Reason for Service Code (Conflict Code) ER- (Drug Overuse Alert) is returned on the rejected claim in field 439-E4, and Other Prescriber Indicator field (533-FX) returned value '2' (Other Prescriber), then the provider name, provider phone number, and provider phone number extension of the Prescriber where the prescription was last filled will be returned in field 570-NS- (DUR Additional Text) on the Response.</p> <p>Note: For all other DUR Reject edits, when the conflict is caused by an "Other Prescriber", eMedNY is not able to provide the identity of that prescriber.</p> <p>(533-FX)</p>
Patient Gender Code	<p>Valid patient gender Codes returned within the Message Field (504-F4) are:</p> <p> F = Female M = Male U = Unborn </p>
Pend Reason Code	<p>The Pend Reason Code returned within the Additional Message Info (526-FQ) indicates that the claim has passed all other online adjudication edits but has been pended for one of the reasons listed in Table 10.</p>
Previous Date of Fill	<p>The Previous Date of Fill returned within the DUR Response.</p> <p>(530-FU)</p>
Quantity of Previous Fill	<p>The Quantity of Previous Fill is returned within the DUR Response area.</p> <p>(531-FV)</p>
Reason for Service Code	<p>The Reason for Service Code returned within the DUR Response area will be generated and sent back to the pharmacy when a DUR conflict is detected. Refer to DUR Processing section for further clarification. The following values may be returned.</p>

FIELD	DESCRIPTION
	<p> TD = Therapeutic Duplication ER = Drug Overuse DD = Drug-Drug Interactions DC = Inferred Drug Disease Precaution PG = Drug Pregnancy Alert PA = Drug Age Precaution LD = Low Dose Alert HD = High Dose Alert NP = New Patient Processing PN = Prescriber Consultation </p> <p>(439-E4)</p>
Recertification Month	The Recertification Month returned within the Message Field (504-F4) is the month the member is due for recertification.
Reject Count	The total number of reject codes being returned. (510-FA)
Reject Codes	A maximum of 5 Reject Codes could be returned if the Claim Response Status is "R" (Reject). Refer to NCPDP Reject Code list for values. (511-FB)
Rx Rejected Code	The Rx Rejected Code returned within the Additional Message Info (526-FQ) provides prescription related reject reasons. Refer to Table 7 .
Service Date	The Service Date returned within the Message Field (504-F4) is the same as the Date Filled (or dispensed), entered on your transaction.
Total Amount Paid	The Total Amount paid for the claim will be returned on the Response. (509-F9)
Transaction Response Status	<p>This is the status for each claim that was submitted. A "C" indicates that the claim is accepted and/or pending, and an "R" indicates that it is rejected. A separate Claim Response Status will be received for each claim submitted on your request (1 - 4). If a "C" is returned, the Authorization Number field must be checked to determine if the claim has been electronically captured for adjudication.</p> <p>The MEVS Pend Response Code Table should also be checked to see if the claim is pending. Refer to Table 10.</p> <p>(112-AN)</p>
Year of Birth	<p>The Year of Birth returned within the Message Field is a 3 digit field formatted as follows:</p> <p>1980 will appear as 980.</p> <p>(504-F4)</p>

7.0 PRO-DUR/ECCA REVERSAL/CANCEL TRANSACTIONS (Rev. 05/11)

This section describes the use of reversal transactions in the Pro-DUR/ECCA system. A reversal transaction is used to cancel or reverse a previously submitted claim that was approved by the Pro-DUR/ECCA system. Reversal transactions can be submitted online up to two years from the service date.

Reversal transactions can only cancel one claim at a time. For example, if four claims were submitted and approved on a single transaction request, four separate reversal transactions would be needed to cancel the entire transaction.

When a reversal transaction is performed on an ECCA transaction that generated a DVS authorization, the DVS authorization is cancelled as well.

The primary matching values used to determine which claim is being canceled are the **Service Provider ID** (201-B1), **Prescription/Service Reference #** (402-D2), and **Date of Service** (401-D1), which were submitted on the original claim. If the reversal is approved, code **021** is returned in the **MEVS Accepted Code**. If no match is found for the reversal, code **045** (No Authorization Found) is returned in the **MEVS Rejected Code**.

The following fields are required for a reversal transaction. Please see the Pro-DUR/ECCA Input Information section for a description of these fields.

BIN Number
Version/Release Number
Transaction Code (B2)
Service Provider ID
Service Provider ID Qualifier
Date of Service
Prescription/Service Reference #
Prescription/Service Reference # Qualifier
Processor Control Number (if a paid claim is being reversed)

The following information is returned if the cancel is accepted.

Transaction Response Status (A)
MEVS Response Code (021)

The following information is returned if the cancel was denied.

MEVS Rejected Code (R)
Rx Rejected Code
Reject Codes (up to 5)

If you need to reverse a previously paid ECCA, paper or electronic batch claim online, you must complete the processor control number field on the reversal transaction. If not completed, the reversal will be rejected with response code 323 (refer to [Table 2](#) codes on page 10.0.1). If you need to reverse a non-ECCA claim, then you may choose to forego entering your processor control number.

8.0 MESSAGE CHARTS (Rev. 12/22)

The following charts are used to illustrate various types of messages you can receive from your transactions. The charts are shown as to content of data. A single chart does not reflect the entire message you will receive in a single response.

Response Message – Chart A

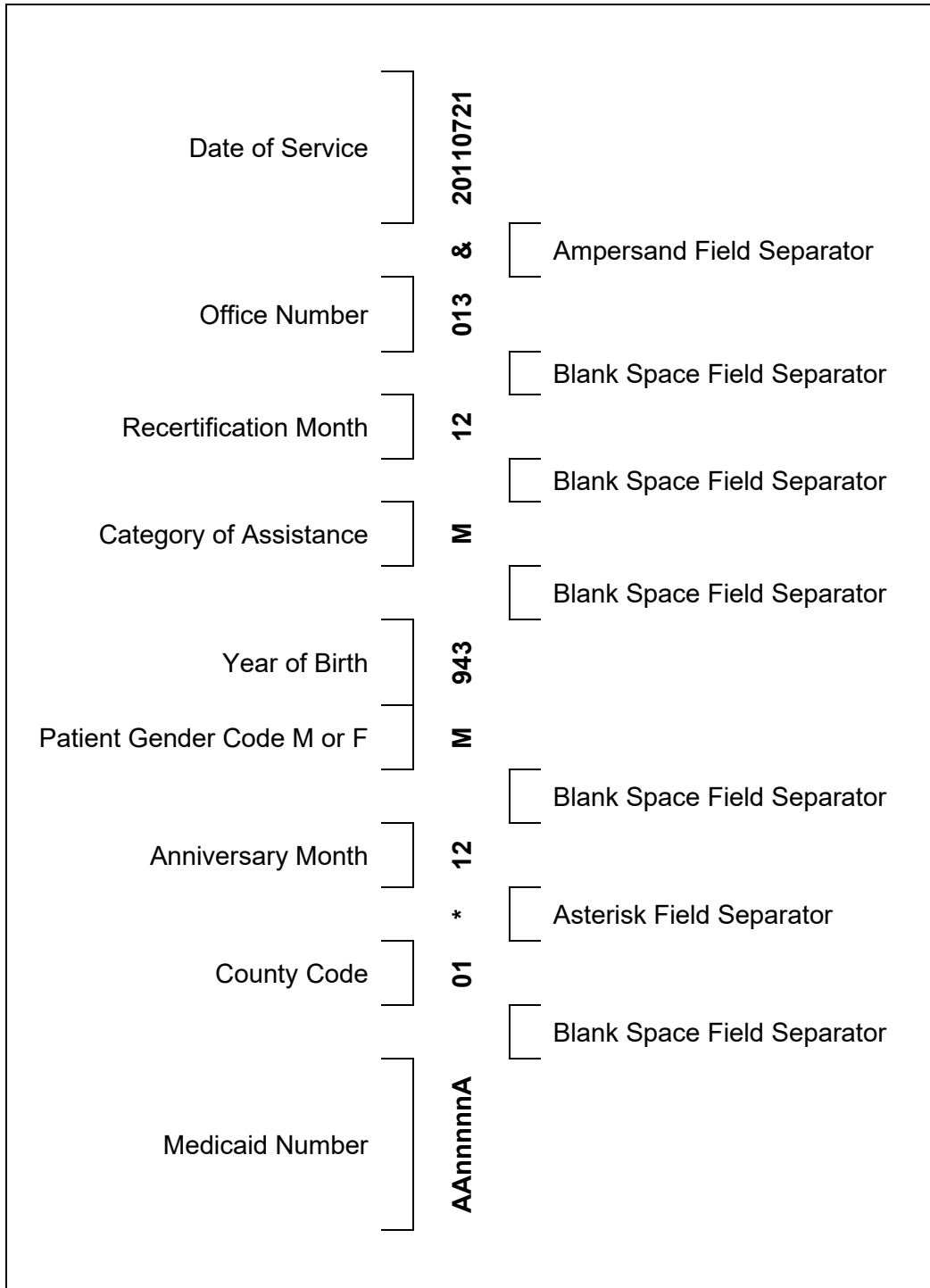

Response Message Segment – Chart A

Additional Message – Chart B

DVS Number	87654321012	
Restriction Information - Exception Codes	} 38 51 35 ZZ	<input type="checkbox"/> Right Bracket Field Separator
Indicator of additional coverage	* ZZ	<input type="checkbox"/> Asterisk Field Separator
2nd Insurance Coverage Code	+ CKP	<input type="checkbox"/> Plus Sign Field Separator
2nd Insurance Carrier Code	/ CD	<input type="checkbox"/> Slash Sign Field Separator
1st Insurance Coverage Code	@ ADEH	<input type="checkbox"/> At Sign Field Separator
1st Insurance Carrier Code	/ BC	<input type="checkbox"/> Slash Sign Field Separator
Medicare Identifier	# XXXXXXXXXXXX	<input type="checkbox"/> Pound Sign Field Separator
Medicare Coverage Code	= AB	<input type="checkbox"/> Blank Space Field Separator
DVS Reason Code (Table 9)	131	<input type="checkbox"/> Equal Sign Field Separator
Co-Payment Met Date	20110430	<input type="checkbox"/> Blank Space Field Separator
Co-Payment Code (Table 6)	127	<input type="checkbox"/> Blank Space Field Separator
Maximum Per Unit Price	% 001.50000	<input type="checkbox"/> Percent Sign Field Separator
Utilization Threshold Code (See Note)	\$ AN	<input type="checkbox"/> Dollar Sign Field Separator
<p>*Note: Effective July 1, 2022, revisions to current law for the Utilization Threshold Program has changed the UT Program to a post payment review process. Your claim will not be denied. The codes being returned in this field will be a place holder.</p>		

Additional Message Segment – Chart B



Rejected Claim Message – Chart C

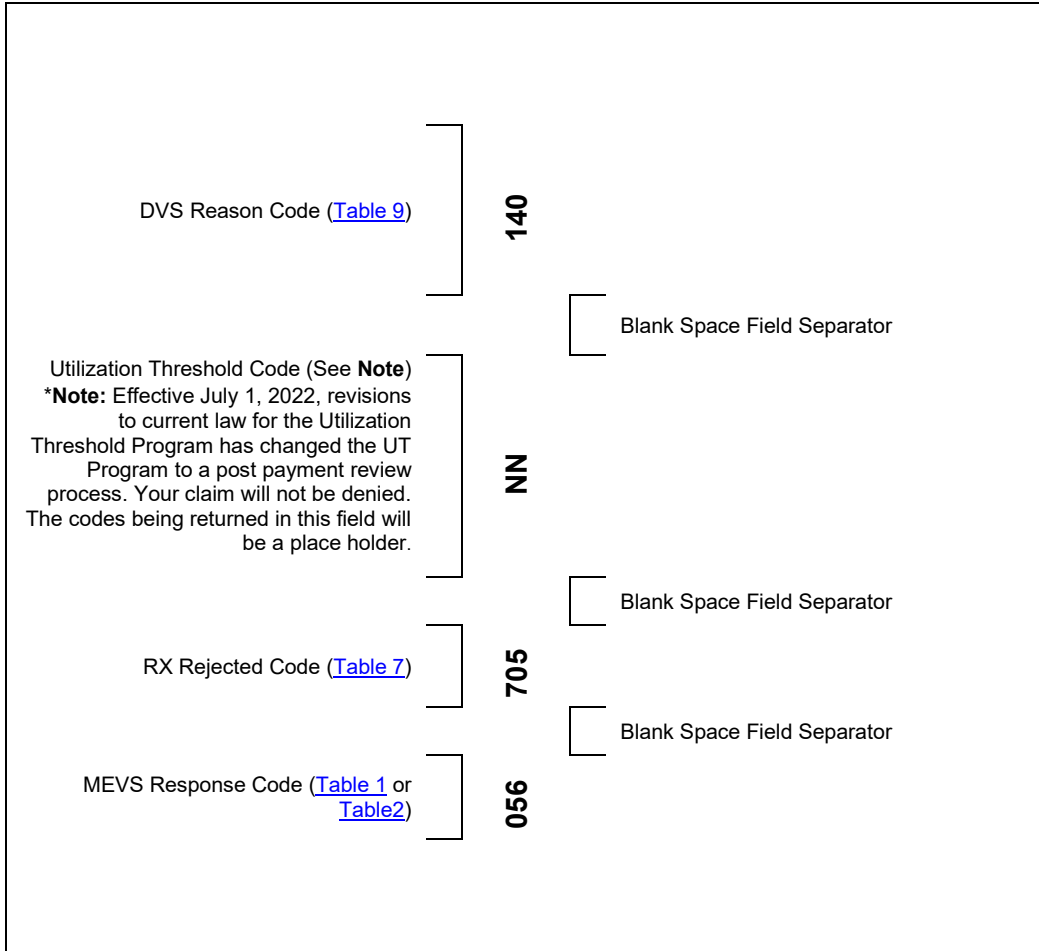

Rejected Claim Message Segment – Chart C

DUR Response – Chart D

DUR Additional Text	For Early Fill Edits only, the following will be returned from the previous conflicting claim: The Other Pharmacy Name, Phone Number, and Phone Number Extension And/or The Other Prescriber Name, Phone Number, and Phone Number Extension
Free Text Area	PROPRANOLOL 10MG TABLET 030
Other Pharmacy Name	1 2 Up to nine DUR Responses can be returned. Rejecteds Come First in the response, then warnings
Phone number	
Other Prescriber Name	
Phone number	
Phone number ext	
Other Prescriber Indicator	
Database Indicator	

DUR Response Segment – Chart D

Quantity of Previous Fill	
Previous Date of Fill	
Other Pharmacy Indicator	3
Clinical Significance	1
Drug Conflict	TD

0000001000
20021106
0000001000

Claim Response Message – Chart E

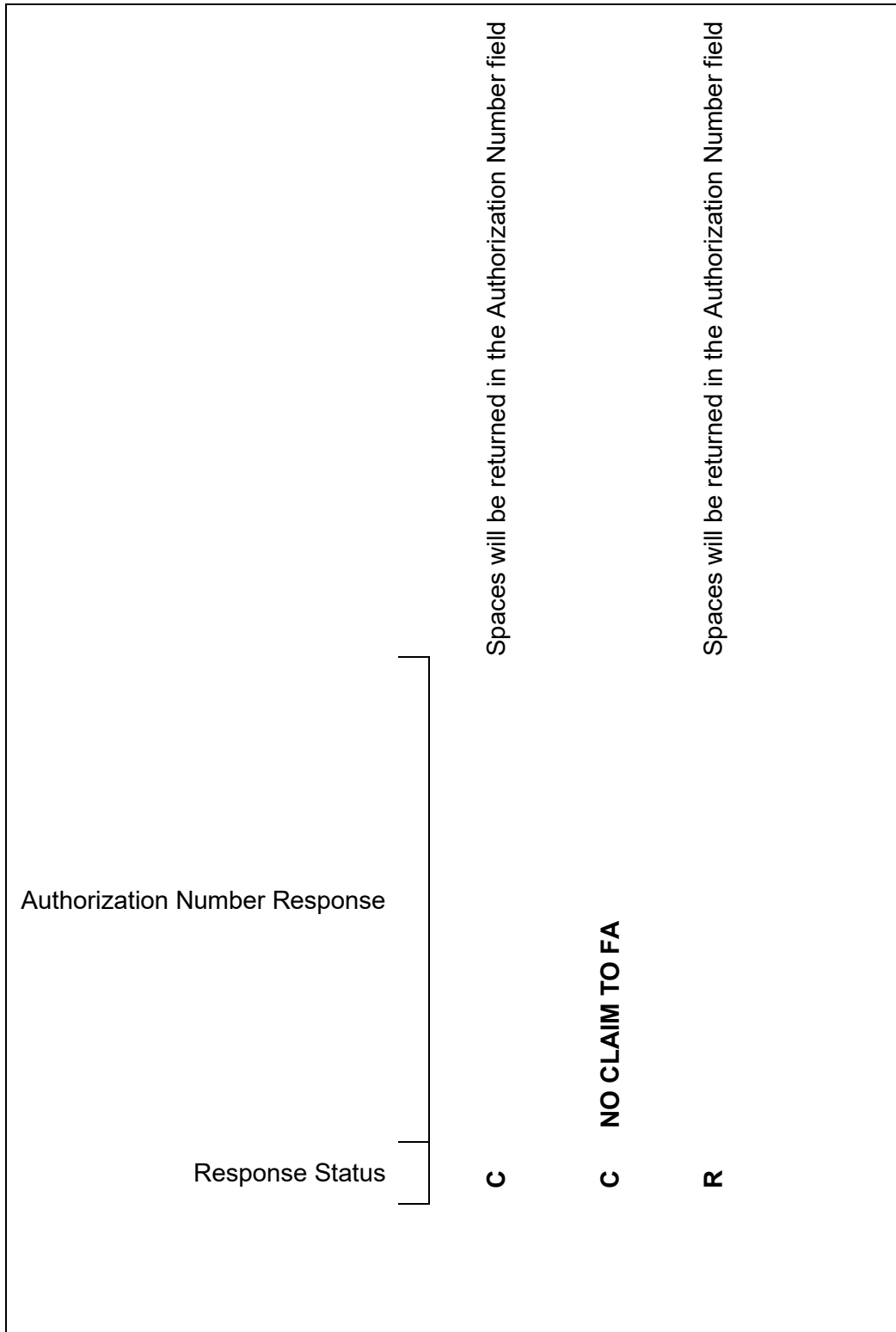

Claim Response Message Segment – Chart E

9.0 MEVS ACCEPTED CODES - TABLE 1 (Rev. 03/24)

All of the Table 1 codes (except 021) indicate the type of Medicaid eligibility for the member. If the member is Medicaid eligible, a Table 1 code will be returned on each claim transaction even if the transaction is rejected for other reasons. (i.e., DUR Rejected, etc.). An exception to this is if the transaction is rejected for header field errors (Code 999 found in [Table 2](#) on page 10.1) and is not processed through the eligibility modules or an invalid Medicaid ID is entered. Another exception is when a pend reason code from [Table 10](#) is warranted in the response. Table 1 codes are eligibility codes. There are no existing comparable NCPDP codes that are returned with these codes.

Code 021 is not an eligibility status code. It is returned if your transaction to cancel a previously accepted claim has been accepted.

Code	Description
002	MA Eligible
006	Eligible PCP
007	Emergency Services Only
008	Presumptive Eligible Long-Term/Hospice
009	Medicare Coinsurance Deductible Only
010	Eligible Except Nursing Facility Services
013	Presumptive Eligibility Prenatal A
014	Presumptive Eligibility Prenatal B
015	Perinatal Family
016	MA Eligible-HR-Utilization Threshold
018	Family Planning Services Only
019	Family Planning Benefit and Medicare Coinsurance and Deductible Only
021	Record Canceled – Cancels a Previously Accepted Claim
034	Community Coverage with Community Based Long Term Care
035	Community Coverage without Long Term Care
221	Eligible PCP with Pharmacy Carve-out
222	Eligible PCP with Mental Health Carve-out
223	Eligible PCP with Mental Health and Pharmacy Carve-out
225	Eligible Family Planning Services No Transportation
226	Eligible Only Inpatient Services
231	Eligible Only Outpatient Care
232	Outpatient Coverage with Community Based Long Term Care
233	Outpatient Coverage without Long Term Care
234	Outpatient Coverage with No Nursing Facility Services

Code	Description
235	Eligible PCP with Family Planning Carve Out (Only)
236	Eligible PCP with Mental Health and Family Planning Carve Out
237	Eligible PCP with Mental Health, Family Planning and Pharmacy Carve Out
238	Eligible PCP with Family Planning and Pharmacy Carve-Out
245	EP – Family Planning and Non- Emergency Transportation Only
255	Eligible PCP, 65 And Over With Pharmacy Carve Out
256	Eligible Fee For Service, 65 And Over, Pharmacy And Emergency Only

10.0 MEVS REJECTED CODES - TABLE 2 (Rev. 03/23)

All of the following codes are MEVS Rejected Codes. Their presence in your response area means the entire transaction has been rejected. If a MEVS Rejected Code has a comparable NCPDP Reject Code, both codes will be returned. If there is no comparable code, then NCPDP code 85, "Claim Not Processed" is returned along with the MEVS Code. In those cases, the MEVS Rejected Code will further qualify the reason for the claim being rejected. The following chart indicates the relationship between the MEVS Rejected Code and any comparable NCPDP Reject Code, if one applies.

Code 999 will be returned if any invalid data is entered in the NCPDP required header fields. For example, an entry of 05 in the **Transaction Code** field will result in an MEVS Rejected Code 999 being returned since it exceeds the number of claims authorized to be sent in a transaction. Also included is a description and relevant comments about the code.

MEVS CODE (526-FQ)	DESCRIPTION	NCPDP CODE (511 – FB)	DESCRIPTION
001	Not MA Eligible	65	Patient is Not Covered
045	No Authorization Found	87	Reversal Not Processed
050	Alternate Access Not Allowed	**	
051	Invalid Provider Number	05	M/I Pharmacy Number
052	Provider Not on File	50	Non-Matched Pharmacy Number
053*	SSN Access Not Allowed	07	M/I Cardholder ID Number
054	Provider Cannot Access by Account Type	**	
055	Provider Not Eligible	889	Prescriber Not Enrolled in State Medicaid Program
056	Re-enter Prescriber Provider Number	25	M/I Prescriber ID
062*	Invalid Medicaid Number	07	M/I Cardholder ID Number
065	Recipient Not on File	52	Non Matched Cardholder ID
066	Disqualified Ordering Provider	25	M/I Prescriber ID
067	Deceased Ordering Provider	25	M/I Prescriber ID
068	Invalid Ordering Provider	889	Prescriber Not Enrolled in State Medicaid Program
071	Invalid Date	15	M/I Date of Service
100*	Invalid Referring Provider Number	35	M/I Primary Care Provider ID
101	Restricted Recipient – No Auth	979 980	Patient Locked into Specific Prescriber(s) Patient Locked into Specific Pharmacy(s)
104	No Coverage: Excess Income	AA	Patient Spenddown Not Met
105	QMB Requires Medicare Approval	AE	QMB (Qualified Medicare Beneficiary) Bill Medicare
118	MCCP Recipient – No Auth	979 980	Patient Locked into Specific Prescriber(s) Patient Locked into Specific Pharmacy(s)
133	Item Not Covered For Patient Gender	61	Drug Not Covered for Patient Gender

MEVS CODE (526-FQ)	DESCRIPTION	NCPDP CODE (511 – FB)	DESCRIPTION
134	Patient Age Exceeds Maximum Age	66	Patient Age Exceeds Maximum Age
135	Patient Age Precedes Minimum Age	60	Product/Service Not Covered for Patient
137	Missing/Invalid Quantity Dispensed	E7	M/I Quantity Dispensed
	Other Payer- Patient Responsibility Value Not Supported	536	Other Payer - Patient Responsibility Amount Qualifier Value Not Supported
	Missing / Invalid Other Payer Reject Code	6E	M/I Other Payer Reject Code
300	Service Date Prior to Birthdate	P6	Date of Service Prior to Date of Birth
302	Provider Ineligible Service on Date Performed	**	
303	Prior Approval Indicated Denied/Rejected by NYS	3Y 75	Prior Authorization Denied Prior Authorization Required
304	Recipient ID Unequal to Prior Approval File	EV	M/I Prior Authorization Number Submitted
305	Child Care Recipient – Bill Agency	**	
307	Prior Approval Units or Payment Amount Exceeded	PA	PA Exhausted/ Not Renewable
308	Service Date Not Within Prior Approval Range	64	Claim Submitted Does Not Match Prior Authorization
309	Claim Type Unequal to Prior Approval Record Class	EV	M/I Prior Authorization ID Submitted
312	Pregnancy Indicated – Invalid for Recipient Sex or Age	**	
313	Provider Reimbursed for Medicare Only	85	Claim Not Processed
314	Recipient Not QMB, Services Not Reimbursable	70	Product/Service Not Covered
315	Recipient Not Medicare, Services Not Reimbursable	70	Product/Service Not Covered
316	Claim Previously Paid Using Another Provider Number	83	Duplicate Paid/ Captured Claim
318	Prescribing Provider/license Not in Active Status	889	Prescriber Not Enrolled in State Medicaid Program
321	Pharmacy Service Included In Out-of-State Facility Rate	**	
322	Online Adjustments/Rebills Not Allowed For DVS Items/Drugs	**	
323	Processor Control Number Needed for Rebill/Reversal of Paid Claim	**	
324	The system or file necessary to process the transaction is currently unavailable.	92	System Unavailable
325	Pharmacy Service included in – In-State Facility Rate	70	Product/Service Not Covered
326	Pend For State Review – OHIP/OIMG	**	

MEVS CODE (526-FQ)	DESCRIPTION	NCPDP CODE (511 – FB)	DESCRIPTION
700*	Year of Birth Not Equal to File	09	M/I Birthdate
701	Sex Not Equal to File	10	M/I Patient Gender Code
702*	ECCA Not Allowed	81 04	Claim too Old M/I Processor Control Number
703*	Invalid PIN	04	M/I Processor Control Number
704*	Invalid ETIN	04	M/I Processor Control Number
729	Denied for Polypharmacy Conflicts	88	DUR Reject Error
999	Header Field Error	***	

* For further explanation and examples of error conditions refer to [Table 2 Error Chart](#)

** NCPDP equivalent reject code does not exist. Code 85 "Claim Not Processed" will be returned.

*** Several Different NCPDP Reject Codes could be returned with MEVS Code 999. These Reject Codes will indicate which header field is in error.

10.1 TABLE 2 ERROR CHART (Rev. 05/11)

The following chart identifies the most common edit failures from the chart above. To assist in troubleshooting, possible reasons are provided for each of these common failures.

MEVS CODE	NCPDP CODE	EXAMPLES OF CORRECT ENTRY	COMMON ERRORS BEING MADE/COMMENTS
053 SSN Access Not Allowed	None	None – 9 digit entry not allowed	The provider does not have rights to perform transactions using the social security number as an identifier.
056 Reenter Ordering Provider Number	25 M/I Prescriber ID		1. The NPI is the only identifier accepted. Do not enter an MMIS ID or License/Profession Code.
062 Invalid Medicaid Number.	07 M/I Cardholder ID Number		<ol style="list-style-type: none"> The entry in the Cardholder ID field must contain the member's 8 character alpha numeric Member ID. The most common error being received that causes code 061 to be returned is an entry of 8 numeric digits in the Cardholder ID field. Check your software to make sure the alpha characters in the Member ID are not being converted to numeric values. Rejections also occur when the ID is not left justified. Code 062 is returned when the number entered cannot be found on the file.
100 Invalid Referring Provider Number	35 M/I Primary Care Provider ID	1234567890 (10 digit National Provider Identification number of the provider to which a member is restricted)	The <u>Primary Care Provider</u> field must contain the 10 digit NPI number that the member is restricted to. This field is <u>in addition</u> to an entry in the <u>Prescriber ID</u> field. The entry must be left justified. The Primary Care Provider ID Qualifier must have a value of 01 when this field is entered.
703 Invalid PIN 704 Invalid ETIN	04 M/I Processor Control Number	YTG1234QBK (Certification, Initials, PIN, ETIN)	<ol style="list-style-type: none"> The reject rejected code 703 will be returned if: <ol style="list-style-type: none"> You have not submitted the PIN selection form to the Department of Health. The PIN number has not been added to your provider file record at the eMedNY contractor. The PIN number transmitted does not match the number selected, which was added to your provider file record. The reject rejected code 704 will be returned if: <ol style="list-style-type: none"> You have not applied for and/or submitted your ETIN number on a notarized certification statement to the eMedNY contractor.

MEVS CODE	NCPDP CODE	EXAMPLES OF CORRECT ENTRY	COMMON ERRORS BEING MADE/COMMENTS
			<p>B.) The ETIN transmitted does not match the ETIN submitted on the certification statement, which was added to the ETIN file.</p> <p>3. Some software has hard coded the ETIN of the billing service into this field. If that ETIN was not on the certification statement, the transaction will reject.</p>
999 Header Field Error	None	None – Please resubmit using NCPDP Version D.0	Used for various Header errors, also used to indicate non-HIPAA compliance.

11.0 CO-PAYMENT CODES - TABLE 6 (Rev. 05/11)

Code	Description
127	Co-payment Requirements Have Been Met
128	No Co-payment Required – Recipient Under 21 or Exempt

12.0 Rx REJECTED CODES - TABLE 7 (Rev. 06/24)

All of the Table 7 codes are rejected codes. Their presence in your response means that the claim has been denied and will appear on a subsequent remittance advice. If none of the Table 7 codes apply to your claim, you will see 000 in your response instead.

MEVS CODE	DESCRIPTION	NCPDP CODE	DESCRIPTION
007	Emergency Services Only	70	Product/Service Not Covered
142	Missing / Invalid category of service	05	M/I Pharmacy Number
421	Dispense Brand Drug Instead of Generic Equivalent	606	Brand Drug/Spec LBLR CD REQRD
705	NDC/APC NOT COVERED	8J	Incorrect Product/Service ID For Processor/Payer
706	Refill Code Exceeds Number of Refills Authorized	17	M/I New Refill Code
707	Previously Filled Refill	83	Duplicate Paid/Captured Claim
708	Exceeds NY Allowed Maximum	78 9G 8Q	Cost Exceeds Maximum Quantity Dispensed Exceeds Maximum Allowed Excessive Refills Authorized
709	Maximum Day's Supply Exceeded	19	M/I Days Supply
710	Maximum Quantity Exceeded	9G	Quantity Dispensed Exceeds Maximum Allowed
713	Refill Over Allowed Days From Date Rx Written	15	M/I Date Filled
		28	M/I Date Prescription Written
717	Client Has Other Insurance	13	M/I Other Coverage Code
718	HR Recipient - No Rebate Agreement	77	Discontinued Product/Service ID Number
719	MA Only Covers Family Planning	65	Patient is Not Covered
720	Days Supply is Less Than Minimum Required	891	Days Supply is Less than Plan Minimum
724	Client Has Medicare Part D	620	PRD/SRV Covered Under Medicare Part D
725	Serial Number Missing	EK	M/I Scheduled Prescription ID Number
728	UR Deny – Conflict With Previous Service	76	Plan Limitations Exceeded
729	Denied for Polypharmacy Conflicts	88	DUR Reject Error
731	UR Deny – Supporting Prior Service Not Found For Claim	85	Claim Not Processed
733	Controlled Substance Oral Prescription Exceeds the Emergency 5 Day Supply Limit	7X	Days Supply Exceeds Plan Limitation
734	Invalid Combination of Values for 340B Drug	34	M/I Submission Clarification Code
738	History Not Found for Administrative Vaccine Claim	85	Claim Not Processed
739	Compound Segment Found with Not Compound Indicator	8D	Compound Segment Present On a Non-Compound Claim

13.0 DISPENSING VALIDATION SYSTEM REASON CODES - TABLE 9 (Rev. 03/23)

CODE	DESCRIPTION
129	Duplicate/Redundant DVS request
130	DVS process was not invoked
131	Item approved / DVS number issued
136	Requested Item Exceeds Frequency Limitations
139	DVS requires current date entry
723	Client Medicare Part D Rejected

14.0 PEND REASON CODES - TABLE 10 (Rev. 11/11)

CODE	DESCRIPTION
301	Pending for Manual Pricing. (The NDC being billed requires manual review and pricing by DOH).
306	Item Requires Manual Review. (The NDC being billed requires manual review by DOH prior to payment). Or the Medicare Paid Amount reported is less than reasonable.
310	Pharmacy Service Included in In-state Facility Rate
311	PCP Plan Code Not on Contract File. (Member is enrolled in a managed care plan but the plan code has not yet been added to DOH's Managed Care Contract file). Call Provider Services 1-800-343-9000.
317	Claim Pending: Excess Income/Spenddown. (Member has income in excess of the allowable Medicaid levels and will be considered eligible for Medicaid reimbursable services only at the point his/her excess income is reduced to the appropriate level. This response will be issued if you override the excess income rejected [code 104] and the LDSS has not yet updated eligibility on the Client database).
319	Prior Approval Not on or Removed From File. (PA is not found on or no longer active on the eMedNY PA file).
321	Pharmacy Service Included in Out of State Facility Rate
326	Pend For State Review – OHIP/OMIG
420	UR Pend – Conflict With Previous Service
422	Pended for Polypharmacy Conflicts
732	UR Pend – Supporting Prior Service Not Found For Claim

Note: These codes may appear in the Table 2 response area for non-ECCA transactions since non-ECCA transactions will not be held in a pending status. They will be rejected if the conditions for these reason codes exist.

15.0 NCPDP REJECT CODES (Rev. 03/24)

CODE (511-FB)	DESCRIPTION (M/I = Missing/Invalid)	MEVS CODE
01	M/I BIN	
04	M/I PROCESSOR CONTROL NUMBER	702, 703, 704
05	M/I PHARMACY NUMBER	051, 092, 142
06	M/I GROUP ID	
07	M/I CARDHOLDER ID NUMBER	030, 031, 033, 062
08	M/I PERSON CODE	063
09	M/I BIRTHDATE	300, 700
10	M/I PATIENT GENDER CODE	701
11	M/I PATIENT RELATIONSHIP CODE	
12	M/I PLACE OF SERVICE	
13	M/I OTHER COVERAGE CODE	717
14	M/I ELIGIBILITY CLARIFICATION CODE	
15	M/I DATE OF SERVICE	071, 713
16	M/I PRESCRIPTION/SERVICE REFERENCE NUMBER	
17	M/I FILL NUMBER CODE	706
18	M/I METRIC QUANTITY	
19	M/I DAYS SUPPLY	
20	M/I COMPOUND CODE	
21	M/I PRODUCT/SERVICE ID	
22	M/I DISPENSE AS WRITTEN CODE (DAW) PRODUCT SELECTION CODE	
23	M/I INGREDIENT COST SUBMITTED (409-D9)	
25	M/I PRESCRIBER ID	059, 066, 067
28	M/I DATE PRESCRIPTION WRITTEN	713
29	M/I NUMBER REFILLS AUTHORIZED	706
31	NO MATCHING PAID CLAIM FOUND FOR REVERSAL REQUEST	
33	M/I PRESCRIPTION ORIGIN CODE	
34	M/I SUBMISSION CLARIFICATION CODE	734
35	M/I PRIMARY CARE PROVIDER ID	100
39	M/I DIAGNOSIS CODE	
41	SUBMIT BILL TO OTHER PROCESSOR OR PRIMARY PAYER	723
50	NON-MATCHED PHARMACY NUMBER	052
52	NON-MATCHED CARDHOLDER ID	065
53	NON-MATCHED PERSON CODE	
56	NON-MATCHED PRESCRIBER ID	
58	NON-MATCHED PRIMARY PRESCRIBER	
60	PRODUCT/SERVICE NOT COVERED FOR PATIENT AGE	135
61	PRODUCT/SERVICE NOT COVERED FOR PATIENT GENDER	133
64	CLAIM SUBMITTED DOES NOT MATCH PRIOR AUTHORIZATION	308
65	PATIENT IS NOT COVERED	001

CODE (511-FB)	DESCRIPTION (M/I = Missing/Invalid)	MEVS CODE
66	PATIENT AGE EXCEEDS MAXIMUM AGE	134
70	PRODUCT/SERVICE NOT COVERED	007, 315, 325
75	PRIOR AUTHORIZATION REQUIRED	303
76	PLAN LIMITATIONS EXCEEDED	136
77	DISCONTINUED PRODUCT/SERVICE ID NUMBER	718
78	COST EXCEEDS MAXIMUM	708
79	REFILL TOO SOON	
80	DRUG DIAGNOSIS CODE MISMATCH	
81	CLAIM TOO OLD	
82	CLAIM IS POST DATED	
83	DUPLICATE PAID/CAPTURED CLAIM	316, 707
84	CLAIM HAS NOT BEEN PAID/CAPTURED	
85	CLAIM NOT PROCESSED	
87	REVERSAL NOT PROCESSED	045
88	DUR REJECT ERROR	
92	SYSTEM UNAVAILABLE	324
1C	M/I SMOKER CODE	
1K	M/I PATIENT COUNTRY CODE	
1R	VERSION NOT SUPPORTED	
1S	TRANSACTION CODE NOT SUPPORTED	
1U	TRXN CNT NOT EQUAL NO OF TRXNS	
1V	MULTIPLE TRXNS NOT SUPPORTED	
1X	VENDOR NOT CERTIFIED FOR PAYOR	
1Y	CLM SEGMNT REQUIRED FOR ADJCTN	
1Z	CLINIC SEGMNT REQ FOR ADJDTN	
201	PATIENT SEGMNT NOT USD ON TRXN	
202	INSRNC SEGMNT NOT USD FOR TRXN	
203	CLAIM SEGMNT NOT USED FOR TRXN	
204	PHARM SEGMNT NOT USED FOR TRXN	
205	PRSCRIBR SEG NOT USED FOR TRXN	
206	COB SEG NOT USED FOR TRXN	
207	WRKR COMP SEG NOT USED ON TRXN	
208	DUR/PPS SEG NOT USED ON TRXN	
209	PRICING SEG NOT USED ON TRXN	
211	COMPOUND SEG NOT USED ON TRXN	
212	PA SEGMNT NOT USED ON TRXN	
213	CLINIC SEGMNT NOT USED ON TRXN	
214	ADDL DOC SGMT NOT USED ON TRXN	
215	FACTLY SGMT NOT USED ON TRXN	
216	NARRTV SGMT NOT USED ON TRXN	

CODE (511-FB)	DESCRIPTION (M/I = Missing/Invalid)	MEVS CODE
217	PURCH SGMT NOT USED ON TRXN	
218	SERV PRVDR SGMT NT USD ON TRXN	
219	PAT ID QUAL NOT USED ON TRXN	
220	PATIENT ID NOT USED ON TRXN	
221	DT OF BIRTH NOT USED ON TRXN	
222	PATIENT GNDER NOT USED ON TRXN	
223	PATIENT FRST NM NT USD ON TRXN	
224	PATIENT LST NM NT USD ON TRXN	
225	PATIENT ADDR NT USD ON TRXN	
226	PATIENT CITY NT USD ON TRXN	
227	PATIENT STATE NT USD ON TRXN	
228	PATIENT ZIP CD NT USD ON TRXN	
229	PATIENT PHNE NO NT USD ON TRXN	
230	PLCE OF SERVICE NT USD ON TRXN	
231	EMPLYR ID NT USD ON TRXN	
232	SMOKER CD NT USD ON TRXN	
233	PREG IND NT USD ON TRXN	
234	PATIENT EMAIL NT USD ON TRXN	
235	PATIENT RESDNCE NT USD ON TRXN	
236	PAT ID ADDR NT USD ON TRXN	
237	CARD HLDR FN NT USD ON TRXN	
238	CARD HLDR LN NT USD ON TRXN	
239	HOME PLAN NT USD ON TRXN	
240	PLAN ID NOT USED ON TRXN	
241	ELIG CLARFCN CD NT USD ON TRXN	
242	GROUP ID NOT USED ON TRXN	
243	PERSON CODE NOT USED ON TRXN	
244	PATNT RLSHP CD NT USD ON TRXN	
246	OTH PYR CTRL NO NT USD ON TRXN	
247	OTH PYR CDHD ID NT USD ON TRXN	
248	OTH PYR GRP ID NT USD ON TRXN	
249	MEDIGAP ID NT USD ON TRXN	
250	MEDICAID IND NT USD ON TRXN	
251	PRVDR ACCP IND NT USD ON TRXN	
252	CMS DEF QUAL FAC NT USD ON TRXN	
253	MEDICAID ID NO NT USD ON TRXN	
254	MEDICAID AGENCY NT USD ON TRXN	
255	RX/SERV REF NO NT USD ON TRXN	
256	RX/SERV DT NT USD ON TRXN	
257	PROC MOD CD CNT NT USD ON TRXN	

CODE (511-FB)	DESCRIPTION (M/I = Missing/Invalid)	MEVS CODE
258	PROC MOD CD NT USD ON TRXN	
259	QUANT DISP NT USD ON TRXN	
26	M/I UNIT OF MEASURE	
260	FILE NO NT USD ON TRXN	
261	DAY SUPPLY NT USD ON TRXN	
262	COMPND CD NT USD ON TRXN	
263	DAW/PSC NT USD ON TRXN	
264	DATE RX WRITTEN NT USD ON TRXN	
265	NO OF REFILL NOT AUTHRZD	
266	RX ORGN CD NT USD ON TRXN	
267	SCC CNT NT USD ON TRXN	
268	SCC NT USD ON TRXN	
269	QTY PRSCRBD NT USD ON TRXN	
27	PRODUCT ID NOT FDA/NSDE LISTED	
270	OTH COV CD NT USD ON TRXN	
271	SPEC TRK CD NT USD ON TRXN	
272	ORIG PRESC PRD/SERV ID NT USD	
273	ORIG PRESC PRD/SERV CD NT USD	
274	ORIG PRESC QTY NT USD ON TRXN	
275	ALTERNATE ID NT USD ON TRXN	
276	SCHED RX ID NT USD ON TRXN	
277	UNIT OF MEASURE NT USD ON TRXN	
278	LEVEL OF SERV NT USD ON TRXN	
279	PA TYPE CD NT USD ON TRXN	
280	PA ID SUBMTD NT USD ON TRXN	
283	DISP STATUS NT USD ON TRXN	
284	QNTY TO BE DISP NT USD ON TRXN	
285	DAY SUPPLY TO BE DISP NT USD	
286	DELAY RSN CD NT USD ON TRXN	
287	TRXN REF NO NT USD ON TRXN	
288	PAT ASSN IND NT USD ON TRXN	
289	ROUTE OF ADMIN NT USD ON TRXN	
290	CMPND TYP NT USD ON TRXN	
291	MCAID SUBJ CNTRL NO NT USD	
292	RX SRVC TYP NT USD ON TRXN	
293	RX/SRVC PRVDR ID QUALFR NT USD	
294	RX/SRVC PRVDR ID NT USD ON TXN	
295	RX/SRVC REF NO QUALFR NT USD	
296	RX/SRVC REF FILL NO NT USD	
297	TIME OF SERVC NT USD ON TRXN	

CODE (511-FB)	DESCRIPTION (M/I = Missing/Invalid)	MEVS CODE
298	SALES TRXN ID NT USD ON TRXN	
299	RPTD ADJ PGM TYP NT USD ON TXN	
2A	M/I MEDIGAP ID	
2B	M/I MEDICAID INDICATOR	
2C	M/I PREGNANCY INDICATOR	
2D	M/I PRVDR ACPT ASSN IND NT USD	
2E	M/I PRIM CARE PROV ID QUALFR	
2G	M/I CMPND ING MODFR CD CNT	
2H	M/I CMPND ING MODFR CD	
2J	M/I PRESCRIBER FIRST NAME	
2M	M/I PRESCRIBER CITY ADDR	
2N	M/I PRESCRIBER STATE/PROVINCE	
2P	M/I PRESCRIBER ZIP/POSTAL ZONE	
2Q	M/I ADDL DOCUMENTATION TYP ID	
2R	M/I LENGTH OF NEED	
2S	M/I LENGTH OF NEED QUALFR	
2T	M/I PRESC/SUPPLR DT SIGNED	
2U	M/I REQUEST STATUS	
2V	M/I REQUEST BEGIN DT	
2W	M/I REQUEST PERIOD/REVSD DT	
2Z	M/I QUEST NO/LETTER CNT	
300	PRVDR ID QUAL NT USD ON TRXN	
301	PRVDR ID NT USD ON TRXN	
302	PRSCRBR ID QUAL NT USD ON TRXN	
303	PRSCRBR ID NT USD ON TRXN	
304	PRSCRBR ID STATE ADDR NT USD	
305	PRSCRBR LST NM NT USD ON TRXN	
306	PRSCRBR PHNE NO NT USD ON TRXN	
307	PRIM CRE PRSCRBR ID QUAL NT USD	
308	PRIM CRE PRSCRBR ID NT USD	
309	PRIM CRE PRSCRBR LST NM NT USD	
310	PRSCRBR FST NME NT USD ON TRXN	
311	PRSCRBR ADDR NT USD ON TRXN	
312	PRSCRBR CITY NT USD ON TRXN	
313	PRSCRBR STATE NT USD ON TRXN	
314	PRSCRBR ZIP/POSTAL ZN NT USD	
315	PRSCRBR ALT ID QUAL NT USD	
316	PRSCRBR ALT ID NT USD ON TRXN	
317	PRSCRBR ALT ID ST ADDR NT USD	
318	OTHR PYR ID QUAL NT USD	

CODE (511-FB)	DESCRIPTION (M/I = Missing/Invalid)	MEVS CODE
319	OTHR PYR ID NT USD ON TRXN	
320	OTHR PYR DT NT USD ON TRXN	
321	INTRNL CNTRL NO NT USD ON TRXN	
322	OTHR PYR AMT PD CNT NT USD	
323	OTH PYR AMT PD QUAL CNT NT USD	
324	OTH PRY AMT PD NT USD ON TRXN	
325	OTH PYR REJ CNT NT USD ON TRXN	
326	OTH PYR REJ CD NT USD ON TRXN	
327	OTHPYR PAT RESP AMT CNT NT USD	
328	OTHPYR PAT RESP AMT QFR NT USD	
329	OTHPYR PAT RESP AMT NT USD	
333	EMPLYR NM NT USD ON TRXN	
334	EMPLYR ADDR NT USD ON TRXN	
335	EMPLYR CITY NT USD ON TRXN	
336	EMPLYR ST NT USD ON TRXN	
337	EMPLYR ZIP NT USD ON TRXN	
338	EMPLYR PHNE NT USD ON TRXN	
339	EMPLYR CNTCT NM NT USD ON TRXN	
340	CARRIER ID NT USD ON TRXN	
341	CLM/REF ID NT USD ON TRXN	
342	BILL ENT TYP IND NT USD ON TXN	
343	PAY TO QUAL NT USD ON TRXN	
344	PAY TO ID NT USD ON TRXN	
345	PAY TO NAME NT USD ON TRXN	
346	PAY TO ADDR NT USD ON TRXN	
347	PAY TO CITY NT USD ON TRXN	
348	PAY TO STATE NT USD ON TRXN	
349	PAY TO ZIP CD NT USD ON TRXN	
350	GNRC EQUIV PRDT ID QUAL NT USD	
351	GNRC EQUIV PRDT ID NT USD	
352	DUR/PPS CD CNTR NT USD ON TRXN	
353	RSN FOR SRVC CD NT USD ON TRXN	
354	PROFSNL SRVC CD NT USD ON TXN	
355	RSLT OF SRVC CD NT USD ON TRXN	
356	DUR/PPS LVL OF EFFRT NT USD	
357	DUR COAGNT ID QUAL NT USD	
358	DUR COAGNT ID NT USD ON TRXN	
359	INGRDNT CST SUBM NT USD	
360	DISP FEE SUBM NT USD ON TRXN	
361	PROFSNL SRVC FEE SUBM NT USD	

CODE (511-FB)	DESCRIPTION (M/I = Missing/Invalid)	MEVS CODE
362	PATIENT PD AMT SUBM NT USD	
363	INCENTIVE AMT SUBM NT USD	
364	OTH AMT CLMD SUBM CNT NT USD	
365	OTH AMT CLMD SUBM QUAL NT USD	
366	OTHAMT CLMD SUBM NT USD ON TXN	
367	FLAT SALES TAX AMT SUBM NT USD	
368	PCT SALES TAX AMT SUBM NT USD	
369	PCT SALES TAX RATE SUBM NT USD	
370	PCT SALESTAX BASIS SUBM NT USD	
371	USUAL/CUSTOMRY CHRG NT USD	
372	GROSS AMT DUE NT USD ON TRXN	
373	BASIS OF COST DETRMNTN NT USD	
374	MEDICAID PD AMT NT USD ON TRXN	
376	CMPD ING DRG CST NT USD ON TXN	
377	CMPD ING BAS CST DTRM NT USD	
378	CMPD ING MOD CD CNT NT USD	
379	CMPD ING MOD CD NT USD ON TXN	
380	AUTH REP FRST NM NT USD ON TXN	
381	AUTH REP LST NM NT USD ON TXN	
382	AUTH REP ADDR NT USD ON TXN	
383	AUTH REP CITY NT USD ON TXN	
384	AUTH REP STATE NT USD ON TXN	
385	AUTH REP ZIP NT USD ON TXN	
386	PA ID ASSGN NT USD ON TXN	
387	AUTH NO NT USD ON TXN	
388	PA SUPPL DOC NT USD ON TXN	
389	DIAG CD CNT NT USD ON TXN	
390	DIAG CD QUAL NT USD ON TXN	
391	DIAG CD NT USD ON TRXN	
392	CLINIC INFO CNT NT USD ON TXN	
393	MEASURMNT DT NT USD ON TXN	
394	MEASURMNT TIME NT USD ON TXN	
395	MEASURMNT DIMENSION NT USD	
396	MEASURMNT UNIT NT USD ON TXN	
397	MEASURMNT VALU NT USD ON TXN	
398	REQ PD BEGIN DT NT USD ON TXN	
399	REQ PD RECERT DT NT USD ON TXN	
3A	M/I REQUEST TYPE	
3B	M/I REQUEST PERIOD DT-BEGIN	
3C	M/I REQUEST PERIOD DT-END	

CODE (511-FB)	DESCRIPTION (M/I = Missing/Invalid)	MEVS CODE
3D	M/I BASIS OF REQUEST	
3E	M/I AUTH REP FIRST NAME	
3F	M/I AUTH REP LAST NAME	
3G	M/I AUTH REP STREET ADDR	
3H	M/I AUTH REP CITY	
3J	M/I AUTH REP STATE	
3K	M/I AUTH REP ZIP/POSTAL CD	
3M	M/I PRESCRBR PHONE NO	
3Q	M/I FACILITY NAME	
3S	M/I PA SUPPORTING DOCS	
3T	ACTV PA EXTS RESUB AFTR PA EXP	
3V	M/I FACILITY STATE	
3W	PA IN PROCESS	
3X	AUTH NO NT FOUND	
3Y	PRIOR AUTHORIZATION DENIED	303
40	PHARM NT CNTRCTD W/PLAN ON DOS	
400	REQ STATUS NT USD ON TXN	
401	LNGTHOFNEED QUAL NT USD ON TXN	
402	LNGTHOFNEED NT USD ON TXN	
403	SUPPLR DT SIGND NT USD ON TXN	
404	SUPPRTG DOCS NT USD ON TXN	
405	QUES NO/LTR CNT NT USD ON TXN	
406	QUES NO/LETTER NT USD ON TXN	
407	QUES PCT RSPNS NT USD ON TXN	
408	QUES DT RSPNS NT USD ON TXN	
409	QUES DLR AMT RSPNS NT USD	
410	QUES NUM RSPNS NT USD	
411	QUES ALPHANUM RSPNS NT USD	
412	FACILITY ID NT USD ON TXN	
413	FACILITY NM NT USD ON TXN	
414	FACILITY ADDR NT USD ON TXN	
415	FACILITY CITY NT USD ON TXN	
416	FACILITY ST NT USD ON TXN	
417	FACILITY ZIP NT USD ON TXN	
418	PURCHSR ID QUAL NT USD ON TXN	
419	PURCHSR ID NT USD ON TXN	
42	PRSCR DB INDS PRSCR ID NACTV	
420	PURCH ID ASSC ST CD NT USD	
421	PURCH DOB NT USD ON TRXN	
422	PURCH GENDR CD NT USD ON TXN	

CODE (511-FB)	DESCRIPTION (M/I = Missing/Invalid)	MEVS CODE
423	PURCH FRST NM NT USD ON TRXN	
424	PURCH LST NM NT USD ON TRXN	
425	PURCH ADDR NT USD ON TRXN	
426	PURCH CITY NT USD ON TRXN	
427	PURCH ST NT USD ON TRXN	
428	PURCH ZIP NT USD ON TRXN	
429	PURCH CNTRY NT USD ON TXN	
43	PRSCRBR DB INDS DEA NO EXPRD	
430	PRCHSR RELSHP CD NT USD ON TXN	
431	RELEASED DT NT USD ON TXN	
432	RELEASED TM NT USD ON TXN	
433	SRVC PRVDR NM NT USD ON TXN	
434	SRVC PRVDR ADDR NT USD ON TXN	
435	SRCV PRVDR CITY NT USD ON TXN	
436	SRVC PRVDR STATE NT USD ON TXN	
437	SRVC PRVDR ZIPCD NT USD ON TXN	
438	SELLER ID QUAL NT USD ON TXN	
439	SELLER ID NT USD ON TXN	
44	PRSCRBR DB INDS DEA NO NTFND	
440	SELLR INITS NT USD ON TXN	
441	OTH AMT CLMD GRPNG INCORRCT	
442	OTH PYR AMT PD GRPNG INCORRCT	
443	OTH PYR PAT RESP AMT GRP INCRT	
445	DIAG CD GRPNG INCORRCT	
446	COB/OTH PYM SEG FRMTNG INCORRT	
447	ADDL DOC SEG FRMTNG INCORRCT	
448	CLINICAL SEGMENT FRMTNG INCRCT	
449	PATIENT SEGMNT FRMTNG INCORRCT	
450	INSRNC SEGMNT FRMTNG INCORRCT	
451	TXN SEGMNT HEADR FRMTNG INCRCT	
452	CLAIM SEGMNT FRMTNG INCORRCT	
453	PHRM PRVDR SEG FRMTNG INCRCT	
454	PRSCRBR SEG FRMTNG INCORRCT	
455	WRKRS COMP SEG FRMTNG INCRCT	
456	PRCNG SEGMNT FRMTNG INCRCT	
458	PRIOR AUTH SGMNT FRMTNG INCRCT	
459	FACILITY SEGMNT FRMTNG INCRCT	
46	DEA CLASS NT ALLWD W/DEA NO	
460	NARRATIVE SEGMNT FRMTNG INCRCT	
461	PURCHASER SEGMNT FRMTNG INCRCT	

CODE (511-FB)	DESCRIPTION (M/I = Missing/Invalid)	MEVS CODE
462	SRVC PRVDR SGMT FRMTNG INCRCT	
463	PHRM NT CNTRCTD IN ASSTLVNGFAC	
464	SPIDQUAL DSNT PREC SRV PRVD ID	
465	PIDQUAL DSNT PREC PAT ID	
466	RX/SRNQUAL DSNT PREC RX/SRN	
467	PRD/SRVIDQ DSNT PREC PRD/SRVID	
468	PRCMODCDCNT DSNT PREC PRCMODCD	
469	SUBCLARCDCNT DSNT PREC SUBCLARCD	
470	SRVIDQ DSNT PREC SRVC CD	
471	OAMTCLMD CNT NPREC OAMTCLMDAMT	
472	OAMTCLMD SUB NPREC OAMTCLMDSUB	
473	PRVDR ID QUAL NPREC PRVDR ID	
474	PRSCRIB ID QUAL NPREC PRSCRIB ID	
475	PCPROVID QUAL NPREC PCPROVID	
476	COB/OPAYCNT NPREC OPAY COV TYP	
478	OPAY IDQUAL NPREC OPAY ID	
479	OPAY AMTPDCNT NPREC OPAY AMTPD	
480	OPAY AMTPDQ NPREC OPAY AMTPD	
481	OPAY REJCNT NPREC OPAY REJCD	
482	OP-PATRESAMTC NP OP-PATRESAMT	
483	OP-PATRESAMTQ NP OP-PATRESAMT	
486	PAYTO QUAL NPREC PAYTO ID	
487	GENEQVPIDQUAL NPREC GENEQVPID	
488	DUR/PPS CDCTR NP DUR DATA FLDS	
489	DURCOAGNTIDQUAL NP DURCOAGNTID	
490	CMP ING CNT NP CMP PRD ID	
491	CMP PRD ID QUAL NP CMP PRD ID	
492	CMPINGMODCDCNT NP CMPINGMODCD	
493	DIAGCDCNT NP DIAGCD/QUAL	
494	DIAGCDQUAL NP DIAG CD	
495	CLCINFCNT NP CLC MEASUR DATA	
496	LNGTHOFNEEDQUAL NP LNGTHOFNEED	
497	QUESTNO/LTRCNT NP QUESTNO/LTR	
498	ACCUM MNTH CNT NP ACCUM MNTH	
4B	M/I QUESTION NUMBER/LETTER	
4C	M/I COB/OTH PYMT CNT	
4D	M/I QUESTION PERCENT RSPNSE	
4E	M/I PRIM CARE PROV LST NME	
4G	M/I QUESTION DT RSPNSE	
4H	M/I QUESTION DOLLAR AMT RSPNSE	

CODE (511-FB)	DESCRIPTION (M/I = Missing/Invalid)	MEVS CODE
4J	M/I QUESTION NUMERIC RSPNSE	
4K	M/I QUESTION ALPHA RSPNSE	
4M	CMPINGMODCDCNT NMTCH NO OF REP	
4N	QUESTNO/LTRCNT NMTCH NO OF REP	
4P	QUESTNO/LTRCNT NT VALD FOR DOC	
4Q	QUEST RESP NAPPRP FOR QUEST NO	
4R	REQ QNO/LTR RESP 4 DOC MISSNG	
4S	CMP PRD ID REQ MOD CD	
4T	M/I ADDL DOCUMENTATION SGMNT	
4W	MUST FILL THROUGH SPECIALTY PHARMACY	
4X	M/I PATIENT RESIDENCE	
4Y	PATIENT RESDNCE VALU NT SUPRTD	
4Z	PLC OF SRVC NT SUPRTD BY PLAN	
500	PIDCNT NP PID DATA FLDS	
505	OTH PAY COV TYPE VALU NT SUPRTD	
506	RX/SRNQUAL VALU NT SUPRTD	
507	ADDL DOC TYP ID VALU NT SUPRTD	
508	AUTH REP ST ADDR NT SUPRTD	
509	BASIS OF REQ VALU NT SUPRTD	
51	NON-MATCHED GROUP ID	
510	BILL ENT TYP IND NT SUPRTD	
511	CMS PT D DQF VALU NT SUPRTD	
512	CMP CD VALU NT SUPRTD	
513	CMP DSP UNT FRM VLU NT SPRTD	
514	CMPINGBOC DET VALU NT SPRTD	
515	CMP PRD ID QUAL VALU NT SPRTD	
516	CMP TYP VALU NT SPRTD	
518	DUR COAGNT ID QUAL VL NT SPRTD	
519	DUR/PPS LVL OF EFF VL NT SPRTD	
520	DELAY RSN CD VALU NT SPRTD	
521	DIAG CD QUAL VALU NT SPRTD	
522	DISP STATUS VALU NT SPRTD	
523	ELIG CLARFCN CD VL NT SPRTD	
524	EMPYR STATE VALU NT SPRTD	
525	FACLTY STATE VALU NT SPRTD	
528	LENGTHOFNEED QUAL VL NT SPRTD	
529	LVL OF SRVC VALU NT SPRTD	
530	MEASURMNT DIM VALU NT SPRTD	
531	MEASURMNT UNIT VL NT SPRTD	
532	MCAID IND VALU NT SPRTD	

CODE (511-FB)	DESCRIPTION (M/I = Missing/Invalid)	MEVS CODE
533	ORIGPRSCPRD/SRVID QVAL NSPRTD	
534	OTH AMT CLM SUB QUAL VL NSPRTD	
535	OTH COV CD VALU NT SPRTD	
536	OTHPYR-PAT RSP AMT QVAL NSPRTD	
537	PAT ASSN IND VALU NT SPRTD	
538	PAT GNDR CD VALU NT SPRTD	
539	PAT ST ADDR VALU NT SPRTD	
540	PAYTOST ADDR VL NT SPRTD	
541	PCT SLSTAX BASIS SUB VL NSPRTD	
542	PREG IND VALU NT SPRTD	
543	PRSCRB ID QVAL NT SPRTD	
544	PRSCRB ST ADDR VL NT SPRTD	
545	RX ORGN CD VALU NT SPRTD	
546	PCP ID QUAL VALU NT SPRTD	
547	PA TYP CD VALU NT SPRTD	
548	PRVDR ACPT PRVDR IND VL NSPRTD	
549	PRVDR ID QUAL VL NT SPRTD	
55	NON-MATCHED PRD PKG SIZE	
550	REQ STATUS VALU NT SPRTD	
551	REQ TYP VALU NT SPRTD	
552	ROUTE OF ADMIN VL NT SPRTD	
553	SMK/NON-SMK CD VL NT SPRTD	
554	SPEC PKG IND VL NT SPRTD	
555	TXN CNT VALU NT SPRTD	
556	UNIT OF MEASURE VALU NT SPRTD	
557	COB SEG PRESNT ON NON-COB CLM	
558	PRTDPLN NO COB W/OTH PRTDPLN	
559	ID SUBM ASSOC W/ EXC PHARM	
560	PHRM NT CNTRCTD IN RTAIL NTRWK	
561	PHRM NT CTRCT IN MAIL OR NTRWK	
562	PHRM NT CTRCT IN HOSPC NTRWK	
563	PHRM NT CTRCT IN VA NTRWK	
564	PHRM NT CTRCT IN MILTRY NTRWK	
565	PAT CNTRY CD VALU NT SPRTD	
566	PAT CNTRY CD NT USD ON TXN	
567	M/I VETERINARY USE IND	
568	VETERINARY USE IND VL NT SPRTD	
569	MCARE RX DRG COV AND UR RIGHTS	
570	VETERNRY USE IND NT USD ON TXN	
571	PAT ID STATE VALU NT SPRTD	

CODE (511-FB)	DESCRIPTION (M/I = Missing/Invalid)	MEVS CODE
572	MEDIGAP ID NOT COVERED	
573	PRSCRBR ALT ID ST VL NT SPRTD	
574	CMP ING MOD CD NT COVRD	
575	PRCHSR ST ADDR VALU NT SPRTD	
576	SRV PRVDR ADDR VALU NT SPRTD	
583	PROVIDER ID NOT COVERED	
584	PRCH ID ASSOC ST VALU NT SPRTD	
585	FILL NO VALU NT SUPPORTD	
586	FACILITY ID NOT COVERED	
587	CARRIER ID NOT COVERED	
588	ALTERNATE ID NOT COVERED	
589	PATIENT ID NOT COVERED	
590	CMP DOSG FORM NOT COVERED	
591	PLAN ID NOT COVERED	
592	DUR COAGENT ID NOT COVERED	
594	PAY TO ID NOT COVERED	
595	ASSOC RX/SRV PRVDR ID NT CVRD	
596	CMP PREP TIME NT USD ON TXN	
597	LTC DISP TYP NT SPRT PCKG TYP	
598	MORE THAN ONE PATIENT FOUND	
599	CRDHLDID MTCH BUT LST NM DIDNT	
5C	M/I OTHER PAYER COVERAGE TYPE	
5E	M/I OTHER PAYER REJECT COUNT	
5J	M/I FACILITY CITY ADDRESS	
600	COVG OUTSIDE SUBM DT OF SRVC	
602	RXPRVDR IDQ NT PRCD RXPRVDR ID	
603	PRSCR ALTIDQ NPRCD PRSCR ALTID	
604	PRCHSR ID QUAL NPRCD PRCHSR ID	
605	SELLR ID QUAL NPRCD SELLR ID	
606	BRND DRG/SPEC LBLR CD REQD	
607	INFO RPTNG TXN NMTCH TO CLM	
608	STPTHROPY REQ PR TO USE OF SUBM PRD ID	
609	COB CLM NREQ-LIABAMT SUBM ZERO	
610	INFO RPT TXN MTCH REJ CLM SUBM	
611	INFORPT MTCH CLM SUBM/PD AS OTC	
613	DISP FREQ MISSNG FOR LTC SHCYC	
614	UPPERCASE CHARS REQUIRED	
615	CMP ING BOS VAL 14 REQ	
616	SCC 8 REQ-CMP ING QTY ZEROS	
617	CMP ING DRG CST CNT BE NEGATVE	

CODE (511-FB)	DESCRIPTION (M/I = Missing/Invalid)	MEVS CODE
619	PRSCRBR TYP 1 NPI REQRD	
620	PRD/SRV CVRD UNDR MEDCRE PT D	724
621	MCAID PAT ELIG FOR MCARE	
623	M/I AUTH REP COUNTRY CD	
624	M/I EMPLYR COUNTRY CD	
625	M/I ENTITY COUNTRY CD	
627	M/I FACILITY COUNTRY CD	
628	M/I PAT ID ASSOC CNTRY CD	
629	M/I PAY TO COUNTRY CODE	
63	PRD/SRV ID NT CVRD FOR INST PAT	
630	M/I PRSCR ALT ID ASSOC CNTRY CD	
631	M/I PRSCR ID ASSOC CNTRY CD	
632	M/I PRESCRIBER CNTRY CD	
633	M/I PRCHSR ID ASSOC CNTRY CD	
634	AUTH REP CNTRY CD VL NSPRTD	
635	EMPLR CNTRY CD VL NT SPRTD	
637	ENTY CNTRY CD VL NT SPRTD	
638	FAC CNTRY CD VALU NT SPRTD	
639	PAT ID ASSOC CNTRY CD VL NSPRTD	
640	PAYTO CNTRY CD VL NT SPRTD	
641	PRSCR ALTID CNTRY CD VL NSPRTD	
642	PRSCR ID CNTRY CD VL NSPRTD	
643	PRSCR CNTRY CD VALU NSPRTD	
644	PRCHID ASSOC CNTRYCD VL NSPRTD	
645	REPKG PRD NT COVRD BY CNTRCT	
646	PAT NELIG-NONPAYMNT OF PREM	
648	QTY RX NMTCH QTY RX ON OG DISP	
649	CUMTV QTY RX NO EXC TOT RX QTY	
650	DOS GT 60DYS FROM DT OF RX LTC	
651	REMS: MDRTY DATA ELMT MSSNG	
652	REMS: PRSCR NMTCH/NENRLLD	
653	REMS: LAT NMTCH/NENRLLD	
654	REMS: PHRM NMTCH/NENRLLD	
655	REMS: MULT PAT MTCHS	
656	REMS: PAT AGE NMTCH	
657	REMS: PAT GNDR NMTCH	
658	REMS: PHRM IS NOT ENRLLD	
659	REMS: PHRM NT RENEW ENRLLMNT	
660	REMS: PHRM NT SUBM AGRMNT FRM	
661	REMS: PHRM SUSP-NONCMPLNCE	

CODE (511-FB)	DESCRIPTION (M/I = Missing/Invalid)	MEVS CODE
662	REMS: PRSCR IS NT ENRLLD	
663	REMS: PRSCR NT CMPL KNWL ASMNT	
664	REMS: PRSCR SUSP-NONCMPLNCE	
665	REMS: EXCESSVE DAYS SPPLY	
666	REMS: INSUFF DAYS SPPLY	
667	REMS: EXCESSVE DOSAGE	
668	REMS: INSUFF DOSAGE	
669	REMS: ADDL FILLS NT PERMITTD	
670	REMS: LAB TEST RESULTS NT DOCD	
671	REMS: LAB TST NT CNDCTD IN TME	
672	REMS: DISP NTAUTH-LAB TST RSLT	
673	REMS: PRSCR CNSG OF PAT NT DOC	
674	REMS: PRSCR NT DOC SFE USE CND	
675	REMS: PRSCR NT DOC PAT OPD TOL	
676	REMS: PRSCR NT DOC PAT CNTP US	
677	REMS: LCKOF CIND THRPY NT DOC	
678	REMS: STEP THERAPY NT DOC	
679	REMS: PRSCR NOT ENRLLD PAT	
680	REMS: PRSCR RENEW PAT ENRLLMNT	
681	REMS: PAT ENRLLMNT REQ NT MET	
682	REMS: PRSCR NT SUBM PAT AGRMNT	
683	REMS:PRSCR NT VRFD PT RPDC POT	
684	REMS: PAT NT DOC SF USE CNDTNS	
685	REMS: PAT NT DOC CMPLT EDCTN	
686	REMS: PAT NT DOC CNTP USE	
687	REMS: ADMINISTRATOR DENIED	
688	REMS: SERVICE BILLING DENIED	
689	PDMP: ADMINISTRATOR DENIED	
69	DOS AFTR COVG TERMD	
690	PDMP: PHARMACY NT CONTRCTD	
691	PDMP: PHARMACY CNTRCT NT RNEWD	
694	PDMP: M/I PAT STREET ADDR	
6C	M/I OTH PYR ID QUALIFIER	
6D	M/I FACILITY ZIP/POSTAL ZONE	
6E	M/I OTHER PAYER REJECT CODE	
6G	COB/OTHPYMT SEG REQ FOR ADJ	
6J	INS SEG REQ FOR ADJ	
6K	PAT SEG REQ FOR ADJ	
6M	PHARM PRVD SEG REQ FOR ADJ	
6N	PRSCR SEG REQ FOR ADJ	

CODE (511-FB)	DESCRIPTION (M/I = Missing/Invalid)	MEVS CODE
6P	PRICING SEG REQ FOR ADJ	
6Q	PRIOR AUTH SEG REQ FOR ADJ	
6R	WORKERS COMP SEG REQ FOR ADJ	
6S	TXN SEG REQ FOR ADJ	
6T	CMP SEG REQ FOR ADJ	
6U	CMP SEG INCORRECT FMT	
6V	MULTI-ING CMP NT SPRTD	
6W	DUR/PPS SEG REQ FOR ADJ	
6X	DUR/PPS SEG INCORRECT FMT	
6Y	NT AUTH TO SUBM ELCTRNCLY	
6Z	PROVIDER NOT ELIGIBLE TO PERFORM SERVICE/ DISPENSE PRODUCT	705
709	M/I RECORD TYPE	
710	DT RECV AFTR RQSTD RESP DT	
711	M/I TRANSMISSION DATE	
712	M/I SENDING ENTITY ID	
713	M/I RECEIVER ID	
714	M/I TRANSMISSION FILE TYPE	
715	M/I TRANSMISSION TYPE	
716	TRANSMISSION FILE TYP NT SPRTD	
717	M/I SUBMISSION NUMBER	
718	M/I AUDIT REQUEST TYPE	
719	AUDIT REQUEST TYPE NT SPRTD	
720	M/I SERVICE PROVIDER CHAIN CD	
721	M/I ENTITY NAME	
722	M/I ENTITY CONTACT FIRST NM	
723	M/I ENTITY CONTACT LAST NM	
724	M/I ENTITY ADDRESS LINE 1	
725	M/I ENTITY ADDRESS LINE 2	
726	M/I ENTITY CITY	
727	M/I ENTITY STATE/PROVINCE ADDR	
728	M/I ENTITY ZIP/POSTAL CODE	
729	M/I ENTITY FAX NUMBER	
73	ADDL FILLS NOT COVERED	
730	M/I ENTITY EMAIL	
731	HDR RESP STATUS NT SPRTD	
732	REJECT CODE NT SPRTD FOR TRNSM	
733	M/I CLAIM SEQUENCE NUMBER	
734	M/I AUDIT CONTROL ID	
735	M/I AUDIT RANGE QUALIFIER	
736	AUDIT RANGE QUAL NT SPRTD	

CODE (511-FB)	DESCRIPTION (M/I = Missing/Invalid)	MEVS CODE
737	M/I AUDIT RANGE START	
738	AUDIT RANGE START NT SPRTD	
739	M/I AUDIT RANGE END	
740	AUDIT RANGE END NT SPRTD	
741	EXCEEDS RANGE START LIMS	
742	EXCEEDS RANGE END LIMS	
743	M/I REQUESTED RESPONSE DT	
744	RESPNS DT REQRS RESCHEDL	
745	M/I EST ARRVL TIME DESCR	
746	EST ARRVL TM REQRS RESCHEDL	
747	M/I AUDIT SPONSOR	
748	NON-MTCHD PROCESSOR CNTL NO	
749	M/I AUDIT ELEMENT TYPE 1	
750	M/I AUDIT ELEMENT TYPE 2	
751	M/I AUDIT ELEMENT TYPE 3	
752	M/I AUDIT ELEMENT TYPE 4	
753	M/I AUDIT ELEMENT TYPE 5	
754	AUDIT ELEMENT TYP NT ALLOW	
755	AUDIT ELEMENT TYP NT REQRD	
756	M/I AUDIT ELEM RESP TYPE 1	
757	M/I AUDIT ELEM RESP TYPE 2	
758	M/I AUDIT ELEM RESP TYPE 3	
759	M/I AUDIT ELEM RESP TYPE 4	
760	M/I AUDIT ELEM RESP TYPE 5	
761	M/I DISCREPANCY CODE 1	
762	M/I DISCREPANCY CODE 2	
763	M/I DISCREPANCY CODE 3	
764	M/I DISCREPANCY MESSAGE	
765	M/I DISCREPANCY AMOUNT	
766	DSCRPNY AMT IN EXC OF CLM AMT	
767	M/I RECORD COUNT	
768	PHARM LOCATION HAS CLOSED	
769	TXN FND-NMTCH W/APPR TXN; REVSL NT PRCS D	
770	TXN NTFND-NMTCH W/APPR TXN; REVSL NT PRCS D	
771	CMP ING UNID-SCC OVRD NT ALLWD	
772	CMP NT PYBL-SCC OVRD NT ALLWD	
777	PRSC DB CNT VRFY LIC 4 PRSC ID	
778	INVALID TRANSMISSION FILE TYPE	
779	INVALID DOCUMENT REF NUMBER	
780	M/I TRANSMISSION TIME	

CODE (511-FB)	DESCRIPTION (M/I = Missing/Invalid)	MEVS CODE
781	CORRUPTD TRANSMISSION CNTRL NO	
782	M/I SENDER ID	
783	M/I RECEIVER ID	
784	M/I FILE TYPE	
785	M/I SUBMISSION NUMBER	
786	M/I TRANSMISSION DATE	
787	M/I ACCUMULATOR BALANCE COUNT	
788	M/I ACCUMULATOR NETWORK IND	
789	M/I ACCUMULATOR ACTION CODE	
790	M/I BENEFIT TYPE	
791	M/I IN-NETWORK STATUS	
792	DUPLICATE RECORD	
793	RETRY LIMIT EXCEEDED	
794	DEDUCTIBLE OVER ACCUMULATED	
795	OUTOFPOCKET OVER ACCUMULATED	
796	MAX BNFIT AMT OVER ACCUMULATED	
798	SA OVER ACCUMULATED	
799	LTC OVER ACCUMULATED	
7A	PRVDR NMTCH AUTH ON FILE	
7B	SRV PRVDRIDQ VL NT SPRTD 4 PYR	
7C	M/I OTHER PAYER ID	
7D	NON-MATCHED DOB	
7E	M/I DUR/PPS CODE COUNTER	
7G	FUTURE DOB NOT ALLOWED	
7J	PAT RLSHP CD VL NT SPRTD	
7N	PAT ID QUAL VL NT SPRTD	
7P	COB/OTHPYM CNT EXC NO SUPP PYR	
7Q	OTH PYR ID QVAL NT SPRTD	
7R	OTHPYRAMTPD CNT EXC NO SUPP GRP	
7T	QTYTB DISP REQ 4 PRTL FILL TXN	
7U	DAY SUPPLY TB DISP REQ 4 PFILL	
7V	DUPLICATE FILL NUMBER	
7W	NUM OF RFILLS EXC ALLWB RFILLS	
7X	DAYS SUPPLY EXCEEDS PLAN LIMITATION	733
7Y	COMPOUNDS NOT COVERED	
800	RXC OVER ACCUMULATED	
801	M/I TOTAL AMOUNT PAID	
802	M/I AMOUNT OF COPAY	
803	M/I PATIENT PAY AMOUNT	
804	M/I AMT ATTRB TO PRD SEL/BRAND	

CODE (511-FB)	DESCRIPTION (M/I = Missing/Invalid)	MEVS CODE
805	M/I AMT ATTRB TO SALES TAX	
806	M/I AMT ATTRB TO PROCESS FEE	
807	M/I INVOICE AMOUNT	
808	M/I PENALTY AMOUNT	
809	MISMATCHED ORIGINAL AUTH	
810	M/I PARTNER ELIGIBILITY DATA	
811	PARTNER ELIGIBILITY MISMATCH	
812	M/I RECORD LENGTH	
813	M/I ACTION CODE	
814	NT SPRTD ACCUM ACTION CD	
815	BALANCE MISMATCH	
816	PHM BEN EXC MYB COV UNDR PAT MEDBEN	
817	PHM BEN EXC COV UNDR PAT MEDBEN	
818	MED ADMIN NT COV; PLN BNFT EXC	
819	PLN ENRL IND MCRE AS PRIM COVG	105
820	MATCHED TO REVERSED/REJECTED CLAIM NOT PART D	
821	MATCHED TO PAID CLAIM NOT PART D	
822	DRUG UNRELATED TO ILLNESS NOT COVERED UNDR HOSPICE	
823	DRUG IS BENEFIC LIAB-NOT COVER BY HOSPICE/PART D	
824	MULTI-TRANS TRANS NOT ALLOWED FOR NCPDP STANDARD	
825	CLAIM DOS OUTSIDE PRODUCT FDA/NSDE MARKETING DATES	
826	NPI SUBMITTED NOT FOUND WITHIN PROCESSORS NPI FILE	068
827	PHARM SVCE PROVIDER TEMP SUSPENDED PROCES CLAIMS	
828	PLAN/BENEFICIARY CASE MGT RESTRICTION IN PLACE	
829	PHARMACY NOTIFY BENEFICIARY: CLAIM NOT COVERED	
830	WORKERS COMP OR P&C ADJUSTER AUTH REQUIRED	
831	PRODUCT SERVICE ID CARVE-OUT BILL MEDICAID FFS	
834	M/I PROVIDER FIRST NAME	
835	M/I PROVIDER LAST NAME	
836	M/I FACILITY ID QUALIFIER	
837	FACILITY ID QUALIFIER VALUE NOT SUPPORTED	
838	M/I ORIGINAL MANUFACTURER PRODUCT ID	
839	M/I ORIGINAL MANUFACTURER PRODUCT ID QUAL	
840	ORIG MANU PROD ID QUALIFIER VALUE NOT SUPPORTED	
841	RECORD IS LOCKED	
842	RECORD IS NOT LOCKED	
843	M/I TRANSMISSION ID	
844	M/I OTHER PAYER ADJUDICATED PROGRAM TYPE	
845	OTHER PAYER RECON ID NOT USED FOR TRANSACTION CODE	
846	BENEFIT STAGE IND CNT NOT USED TRANSACTION CODE	

CODE (511-FB)	DESCRIPTION (M/I = Missing/Invalid)	MEVS CODE
847	BENE STAGE IND CNT DOES NOT PRECEDE BENE STAGE IND	
848	M/I BENEFIT STAGE INDICATOR COUNT	
849	BENE STAGE IND COUNT NOT MATCH NUMBER REPETITIONS	
850	BENEFIT STAGE INDICATOR NOT USED FOR TRANS CODE	
851	BENEFIT STAGE INDICATOR VALUE NOT SUPPORTED	
852	M/I BENEFIT STAGE INDICATOR	
853	N PAYER IIN IS NOT USED FOR THIS TRANSACTION CODE	
854	M/I N PAYER IIN	
855	NON-MATCHED N PAYER IIN	
856	N PAYER PROC CNTRL NUMBER NOT FOR TRANSACTION CODE	
857	M/I N PAYER PROCESSOR CONTROL NUMBER	
858	NON-MATCHED N PAYER PROCESSOR CONTROL NUMBER	
859	N PAYER GROUP ID NOT USED FOR TRANSACTION CODE	
86	SUBMIT MANUAL REVERSAL	
860	M/I N PAYER GROUP ID	
861	NON-MATCHED N PAYER GROUP ID	
862	N PAYER CARDHOLDER ID NOT USED TRANSACTION CODE	
863	M/I N PAYER CARDHOLDER ID	
864	N PAYER CARDHOLDER ID IS NOT COVERED	
865	N PAYER ADJUDICATED PGM TYPE NOT FOR TRANS CODE	
866	M/I N PAYER ADJUDICATED PROGRAM TYPE	
867	N PAYER ADJUDICATED PROGRAM TYPE NOT SUPPORTED	
868	M/I N TRANSACTION RECONCILIATION ID	
869	M/I N TRANSACTION SOURCE TYPE	
870	M/I PRESCRIBER DEA NUMBER	
871	M/I COMPOUND LEVEL OF COMPLEXITY	
872	MISMATCH COMPOUND LOC AND PREPARATION ENVIRONMENT	
873	M/I PREPARATION ENVIRONMENT TYPE	
874	M/I PREPARATION ENVIRONMENT EVENT CODE	
875	M/I TOTAL PRESCRIBED QUANTITY REMAINING	
876	PRESCRIPTIVE AUTH RESTRICTIONS CRITERIA NOT MET	
877	SERVICE PROVIDER ID TERMINATED ON NPPES FILE	
878	SERVICE PROVIDER ID NOT FOUND ON NPPES FILE	
879	SRVC PROVIDER ID EXCLUDED FROM CMS ENROLLMENT DATA	
880	M/I SUBMISSION TYPE CODE	
881	M/I SUBMISSION TYPE CODE COUNT	
882	M/I DO NOT DISPENSE BEFORE DATE	
883	DATE OF SERVICE PRIOR TO DO NOT DISPENSE DATE	
884	M/I MULTIPLE RX ORDER GROUP REASON CODE	
885	M/I MULTIPLE RX ORDER GROUP ID	

CODE (511-FB)	DESCRIPTION (M/I = Missing/Invalid)	MEVS CODE
886	M/I PRESCRIBER PLACE OF SERVICE	
887	PREVIOUS PAYER EXCLUDED FHCP COPAY NOT ALLOWED	
888	BENEFICIARY IS ENROLLED IN EXCLUDED FHCP	
889	PRESCRIBER NOT ENROLLED IN STATE MEDICAID PROGRAM	055, 318, 068
890	PHARMACY NOT ENROLLED IN STATE MEDICAID PROGRAM	
891	DAYS SUPPLY IS LESS THAN PLAN MINIMUM	720
892	PHARMACY MUST ATTEST FDA REMS RQMNTS HAVE BEEN MET	
893	PHARMACY MUST ATTEST RQURED PATIENT FORM ON FILE	
894	PHARMACY MUST ATTEST MEDICAL NECESS HAS BEEN MET	
895	ALLOWED NUMBER OF OVERRIDES EXHAUSTED	
896	ADJUDICATED PROGRAM TYPE OF UNKNOWN IS NOT COVERED	
897	M/I REGULATORY FEE COUNT	
898	M/I REGULATORY FEE TYPE CODE	
899	M/I OTHER PAYER PERCENTAGE TAX EXEMPT INDICATOR	
8B	COMPOUND SEGMENT MISSING ON A COMPOUND CLAIM	
8C	M/I FACILITY ID	
8D	COMPOUND SEGMENT PRESENT ON A NON-COMPOUND CLAIM	
8E	M/I DUR/PPS LEVEL OF EFFORT	
8G	PRODUCT/SERVICE ID MUST BE ZERO FOR COMPOUNDS	
8H	PRODUCT/SERVICE ONLY COVERED ON COMPOUND CLAIM, 407-D7	
8J	INCORRECT PRODUCT/SERVICE ID FOR PROCESSOR/PAYER	
8K	DAW CODE VALUE NOT SUPPORTED	
8M	SUM CMPND INGRED COST NOT EQUAL INGRED COST SUBT	
8N	FUTURE DATE PRESCRIPTION WRITTEN NOT ALLOWED	
8P	DATE WRITTEN DIFFERENT ON PREVIOUS FILL	
8Q	EXCESSIVE REFILLS AUTHORIZED	708
8R	SUBMISSION CLARIFICATION CODE VALUE NOT SUPPORTED	
8S	BASIS OF COST DETERMINATION VALUE NOT SUPPORTED	
8T	U&C MUST BE GREATER THAN ZERO	
8U	GAD MUST BE GREATER THAN ZERO	
8W	DISCREPANCY OTHER COV CODE AND OTHR PAYER AMOUNT	
8X	COLLECTION FROM CARDHOLDER NOT ALLOWED	
8Y	EXCESSIVE AMOUNT COLLECTED	
8Z	INCORRECT PRODUCT/SERVICE ID FOR PROCESSOR/PAYER	705
90	HOST HUNG UP	
900	M/I OTHER PAYER REGULATORY FEE TYPE COUNT	
901	M/I OTHER PAYER REGULATORY FEE TYPE CODE	
902	M/I OTHER PAYER REGULATORY FEE EXEMPT INDICATOR	
903	REGULATORY FEE CNT NOT USED FOR TRANSACTION CODE	
904	REG FEE TYPE CODE NOT USED FOR TRANSACTION COD	

CODE (511-FB)	DESCRIPTION (M/I = Missing/Invalid)	MEVS CODE
905	OTH PYR PERCNT TAX EXMPT IND NOT TRANS CODE	
906	OTHR PAYR REG FEE TYPE COUNT NOT FOR TRANS COD	
907	OTHR PAYR REG FEE TYPE CODE NOT FOR TRANS CODE	
908	OTHR PAYR FEE EXEMT IND NOT FOR TRANS CODE	
909	REGULATORY FEE GROUPING NOT CORRECT	
91	HOST RESPONSE ERROR	
910	OTHER PAYER REGULATORY FEE GROUPING NOT CORRECT	
911	REG FEE COUNT NOT MATCH NUMBER OF REPETITION	
912	OTHER PAYR REG FEE COUNT NOT MATCH NO OF REP	
913	REG FEE COUNT EXCEED NUMBER OF OCCURRENCES	
914	OTHR PAYR REG FEE TYPE COUNT EXCEEDS OCCUR	
915	REG FEE TYP CD NOT PRECED REG FEE AMNT SUB	
916	OTH PYR REG FE NOT PRE OTH PYR REG FE EXPT	
917	REG FEE CNT DOES NOT PRECEDE REG FEE TYPE	
918	OTHR PYR REG FEE CNT NOT PRECD REG FEE TYP	
919	REGULATORY FEE TYPE CODE NOT SUPPORTED	
920	OTH PYR REGUL FEE TYPE CODE NOT SUPPORTED	
921	OTHR PAYR REG FEE EXMPT IND NOT SUPPORTED	
922	MORPHINE MG EQUIVALENCY EXCEEDS LIMITS	
923	MORPHINE MG EQUIVALENCY EXCEEDS LIMIT AGE	
924	CUM DOSE EXCEEDED ACROSS MULTI PRESCRIPT	
925	INITIAL FILL DAYS SUPPLY EXCEEDS LIMITS	
926	INITIAL FILL DAYS SUPPLY EXCEEDS LIMITS AGE	
927	DAY SUPPLY LIMT FOR PROD/SERV PATIENT AGE	
928	CUMULATIVE FILLS EXCEED LIMITS	
929	ID SUBMITTED ASSOCIATED WITH PRECLUDED PRESCRIBER	
930	ID SUBMITTED IS ASSOCIATED TO A PRECLUDED PHARMACY	
931	M/I SENDING ENTITY NAME	
932	M/I PATIENT MIDDLE NAME	
933	M/I PATIENT NAME SUFFIX	
934	M/I PATIENT NAME PREFIX	
935	M/I ELECTRONIC PRESCRIPTION MESSAGE ID	
936	M/I ELECTRONIC PRESCRIBER ORDER NUMBER	
937	M/I STATE ISSUING SCHEDULED PRESCRIPTION ID NUMBER	
938	M/I PRESCRIBER MIDDLE NAME	
939	M/I SERVICE PROVIDER CONTACT FIRST NAME	
940	M/I SERVICE PROVIDER CONTACT LAST NAME	
941	M/I SERVICE PROVIDER TELEPHONE NUMBER	
942	M/I SPECIES	
943	DUR REJECT-PHARM OVERR USING DUR/PPS NOT ALLOWED	

CODE (511-FB)	DESCRIPTION (M/I = Missing/Invalid)	MEVS CODE
944	ALL LOTS OF DRUG/PRODUCT RECALLED	
945	HIGH DOLLAR AMOUNT IS NOT SUPPORTED	
946	LAST KNOWN 4RX CLAIM DATE SUBMITTED TOO OLD	
95	TIME OUT	
96	SCHEDULED DOWNTIME	
97	PAYER UNAVAILABLE	
979	PATIENT LOCKED INTO SPECIFIC PRESCRIBER(S)	101, 118
98	CONNECTION TO PAYER IS DOWN	
980	PATIENT LOCKED INTO SPECIFIC PHARMACY(S)	101, 118
981	DOS FILL EXCEEDS REG TIMEFRAME FOR DISPENSING	
982	PROVIDE PATIENT NOTICE WHEN ACCESS IS DELAYED	
984	BILL DUAL ELIG MEDICARE B ALT MEDICAID BENEFIT	
985	BENEFICIARY HAS WORKERS COMP MEDI SET-ASIDE ARRANG	
986	M/I SEX ASSIGNED AT BIRTH	
987	SEX ASSIGNED AT BIRTH VALUE NOT SUPPORTED	
99	HOST PROCESSING ERROR	
997	PRESC/SERV REF QUAL DOES NOT PRECED PRESC/SERV REF	
998	BENEFIT STAGE IND COUNT EXCEEDS NUMBER SUPPORTED	
999	M/I EMPLOYER CONTACT FIRST NAME	
9D	RESULT OF SERVICE CODE VALUE NOT SUPPORTED	
9G	QUANTITY DISPENSED EXCEEDS MAXIMUM ALLOWED	708, 710
9J	FUTURE OTHER PAYER DATE NOT ALLOWED	
9K	COMPOUND INGRED COUNT EXCEEDS NUMBER OF INGRED SUP	
9M	MINIMUM OF TWO INGREDIENTS REQUIRED	
9N	COMPOUND INGREDIENT QUNTY EXCEEDS MAXIMUM ALLOWED	
9Q	ROUTE OF ADMINISTRATION SUBMITTED NOT COVERED	
9R	PRESCR/SER REF NUMBER QUALIFIER SUBMIT NOT COVERED	
9S	FUTURE ASSOCIATED PRESCRIPT/SERV DATE NOT ALLOWED	
9T	PRIOR AUTHORIZATION TYPE CODE SUBMITTED NOT COVERED	
9U	PROVIDER ID QUALIFIER SUBMITTED NOT COVERED	
9V	PRESCRIBER ID QUALIFIER SUBMITTED NOT COVERED	
9W	DUR/PPS CODE COUNTER EXCEEDS NUMBER SUPPORTED	
9Y	COMPOUND PRODUCT ID QUALIFIER SUBMITTED NOT COVERED	
A1	ID SUBMITTED ASSOCIATED WITH EXCLUDED PRESCRIBER	
A2	ID SUBMITTED IS ASSOCIATED TO DECEASED PRESCRIBER	
A3	PRODUCT MAY BE COVERED UNDER HOSPICE - MEDICARE A	
A4	PROD COVERED MEDI-B PMT TO ESRD DIALYSIS FACILITY	
A5	NOT COVERED UNDER PART D LAW	
A9	M/I TRANSACTION COUNT	
AA	PATIENT SPENDDOWN NOT MET	104

CODE (511-FB)	DESCRIPTION (M/I = Missing/Invalid)	MEVS CODE
AB	DATA WRITTEN AFTER DATE OF SERVICE	
AE	QMB (QUALIFIED MEDICARE BENEFICIARY) BILL MEDICARE	105
AF	PATIENT ENROLLED UNDER MANAGED CARE	
AG	DAYS SUPPLY LIMITATION FOR PRODUCT/SERVICE	
AH	DOSE PACKAGING ONLY PAYABLE FOR NURSING HOME RECIP	
AJ	GENERIC DRUG REQUIRED	
AK	M/I SOFTWARE VENDOR/CERTIFICATION ID	
AM	M/I SEGMENT IDENTIFICATION	
AQ	M/I FACILITY SEGMENT	
B2	M/I SERVICE PROVIDER ID QUALIFIER	
BA	COMPOUND BASIS OF COST DETERMINATION NOT COVERED	
BB	DIAGNOSIS CODE QUALIFIER SUBMITTED NOT COVERED	
BC	FUTURE MEASUREMENT DATE NOT ALLOWED	
BE	M/I PROFESSIONAL SERVICE FEE SUBMITTED	
BM	M/I NARRATIVE MESSAGE	
CA	M/I PATIENT FIRST NAME	
CB	M/I PATIENT LAST NAME	
CC	M/I CARDHOLDER FIRST NAME	
CD	M/I CARDHOLDER LAST NAME	
CE	M/I HOME PLAN	
CF	M/I EMPLOYER NAME	
CH	M/I EMPLOYER CITY ADDRESS	
CI	M/I EMPLOYER STATE/PROVINCE ADDRESS	
CJ	M/I EMPLOYER ZIP POSTAL ZONE	
CK	M/I EMPLOYER PHONE NUMBER	
CN	M/I PATIENT CITY ADDRESS	
CO	M/I PATIENT STATE/PROVINCE ADDRESS	
CP	M/I PATIENT ZIP/POSTAL ZONE	
CQ	M/I PATIENT PHONE NUMBER	
CR	M/I CARRIER ID	
CW	M/I ALTERNATE ID	
CX	M/I PATIENT ID QUALIFIER	
CZ	M/I EMPLOYER ID	
DA1	M/I EMPLOYER CONTACT LAST NAME	
DA2	M/I EMPLOYER STREET ADDRESS LINE 1	
DA3	M/I EMPLOYER STREET ADDRESS LINE 2	
DA4	M/I EMPLOYER TELEPHONE NUMBER EXTENSION	
DA5	M/I FACILITY STREET ADDRESS LINE 1	
DA6	M/I FACILITY STREET ADDRESS LINE 2	
DA7	M/I NUMBER OF LTPAC DISPENSING EVENTS	

CODE (511-FB)	DESCRIPTION (M/I = Missing/Invalid)	MEVS CODE
DA8	M/I PATIENT STREET ADDRESS LINE 1	
DA9	M/I PATIENT STREET ADDRESS LINE 2	
DB1	M/I RECONCILIATION ID	
DB2	M/I SUBROGATION AMOUNT REQUESTED	
DB3	M/I PAY TO STREET ADDRESS LINE 1	
DB4	M/I PAY TO STREET ADDRESS LINE 2	
DB5	FACILITY ID QUALIFIER DOES NOT PRECEDE FACILITY ID	
DB6	M/I LTPAC BILLING METHODOLOGY	
DB7	LTPAC BILLING METHODOLOGY VALUE NOT SUPPORTED	
DB8	M/I LTPAC DISPENSE FREQUENCY	
DB9	LTPAC DISPENSE FREQUENCY VALUE NOT SUPPORTED	
DC	M/I DISPENSING FEE SUBMITTED	
DC1	ORIG PROD ID QUALIF DOES NOT PRECEDE ORIG PROD ID	
DC2	PATIENT ID COUNTRY CODE NOT USED TRANSACTION CODE	
DC3	PATIENT NAME PREFIX IS NOT FOR TRANSACTION CODE	
DC4	PATIENT NAME SUFFIX NOT FOR TRANSACTION CODE	
DC5	PRESCRIBER ALT ID CTRY CODE NOT USED TRANS CODE	
DC6	PRESCRIBER ID ASSOCIATED CTRY CODE NOT TRANS CODE	
DC7	RECONCILIATION ID NOT USED THIS TRANSACTION CODE	
DC8	SUBMISSION TYP CODE COUNT NOT USED FOR TRANS CODE	
DC9	SUB TYPE CODE COUNT DOES NOT PRECEDE SUB TYPE CODE	
DD1	SUBMISSION TYPE CODE COUNT EXCEEDS OCCURRENCES	
DD2	SUBMISSION TYPE CODE COUNT NOT MATCH REPETITIONS	
DD3	PATIENT ID COUNT NOT USED FOR TRANSACTION CODE	
DD4	PATIENT ID COUNT EXCEEDS NUMBER SUPPORTED	
DD5	PATIENT ID GROUPING IS INCORRECT	
DD6	PATIENT MIDDLE NAME NOT USED FOR TRANSACTION CODE	
DD7	PRESCRIBER MIDDLE NAME NOT USED TRANSACTION CODE	
DD8	M/I PRESCRIBER STREET ADDRESS LINE 1	
DD9	M/I PRESCRIBER STREET ADDRESS LINE 2	
DE1	M/I PRESCRIBER TELEPHONE NUMBER EXTENSION	
DE2	COB CONFLICT-OPI MUST CONTAIN FINAN OR REJECT CODE	
DE3	PROFESS SVCE NOT COVERED - PLAN/BENEFIT EXCLUSION	
DE4	PROF SRV CD REQR WHEN INCENT FEE ON NON-VACC PROD	
DE5	HOSPICE NX NOT SUPPORTED	
DE6	HOSPICE CLIN INFO CTR NOT MATCH TRANS CODE SUBMITTED	
DE7	NO HOSPICE ENROLLMENT FOUND FOR THIS NPI	
DE8	HOSPC PRS CRT/SVC REF NUM NOT MATCH TRANS CD SUBMIT	
DE9	MEMBER REFUSAL OF PRODUCT - CONTACT PLAN ONLY	
DF1	PHARM LOCKED OUT MEMBER REQUEST-CONTACT PLAN ONLY	

CODE (511-FB)	DESCRIPTION (M/I = Missing/Invalid)	MEVS CODE
DF2	PRESCRIB LOCKED OUT MEMB REQUEST-CONTACT PLAN ONLY	
DF3	REVERSAL REQUEST SUBMITTED OUT OF ORDER FOR COB	
DF4	INVALID LTPAC DISPENSE FREQUENCY AND SCC COMBO	
DF5	BENEFIT STAGE INDICATOR GROUPING INCORRECT	
DF6	CLINICAL INFORMATION GROUPING INCORRECT	
DF7	COMPOUND INGREDIENT GROUPING INCORRECT	
DF8	COMPOUND INGREDIENT MODIFIER GROUPING INCORRECT	
DF9	COORDINATION OF BENEFITS GROUPING INCORRECT	
DG1	DUR GROUPING INCORRECT	
DG2	INTERMEDIARY GROUPING INCORRECT	
DG3	OTHER PAYER REJECT GROUPING INCORRECT	
DG4	PROCEDURE MODIFIER GROUPING INCORRECT	
DG5	ADDITIONAL DOCUMENTATION QUESTION GROUPI INCORRECT	
DG6	SUBMISSION CLARIFICATION CODE GROUPING INCORRECT	
DG7	SUBMISSION TYPE CODE GROUPING INCORRECT	
DG8	M/I INTERMEDIARY ID	
DG9	M/I INTERMEDIARY ID COUNT	
DH1	M/I INTERMEDIARY ID COUNTRY CODE	
DH2	M/I INTERMEDIARY ID STATE PROVINCE ADDRESS	
DH3	M/I INTERMEDIARY ID QUALIFIER	
DH4	M/I INTERMEDIARY ID TYPE CODE	
DH5	M/I INTERMEDIARY ID TYPE ENTITY	
DH6	M/I OTHER PAYER RECONCILIATION ID	
DH7	INTERMEDIARY ID COUNT NOT MATCH NUMBER OF REPS	
DH8	INTERMEDIARY ID COUNT NOT PRECEDE INTERMEDIARY ID	
DH9	INTERMEDIARY ID QUAL NOT PRECEDE INTERMEDIARY ID	
DI1	INTERMEDIARY SEGMENT INCORRECTLY FORMATTED	
DI2	PROD/SERVICE ID QUALIFIER MUST BE 00 FOR COMPOUNDS	
DI3	GROUP SEPARATOR NOT USED FOR THIS VERSION/RELEASE	
DI4	SUBMISSION TYPE CODE VALUE NOT SUPPORTED	
DI5	PLACE OF SERVICE VALUE NOT SUPPORTED	
DI6	SPECIES VALUE NOT SUPPORTED	
DI7	PRESCRIBER PLACE OF SERVICE VALUE NOT SUPPORTED	
DI8	OTHER PAYER ADJUDICATED PGM TYP VALU NOT SUPPORTED	
DI9	OTHER PAYER AMOUNT PAID QUALI VALUE NOT SUPPORTED	
DJ1	OTHER PAYER PERCENT TAX EXEMPT IND VALU NOT SPRTED	
DJ2	PROCEDURE MODIFIER CODE VALUE NOT SUPPORTED	
DJ3	MULTI PRESCRT/SERV ODR GRP REASON CD VALU NOT SUPP	
DJ4	PREPARATION ENVIRONMENT TYPE VALUE NOT SUPPORTED	
DJ5	PREPARATION ENVIRON EVENT CODE VALUE NOT SUPPORTED	

CODE (511-FB)	DESCRIPTION (M/I = Missing/Invalid)	MEVS CODE
DJ6	ORIGINAL MANU PRODUCT ID QUAL VALUE NOT SUPPORTED	
DJ7	LTPAC DISPENSE FREQUENCY VALUE NOT SUPPORTED	
DJ8	LTPAC BILLING METHODOLOGY VALUE NOT SUPPORTED	
DJ9	COMPOUND DOSAGE FORM DESCRIPT CODE VAL NOT SUPPORT	
DK1	COMPOUND INGREDIENT MOD CODE VALUE NOT SUPPORTED	
DK2	COMPOUND LEVEL OF COMPLEXITY VALUE NOT SUPPORTED	
DK3	INTERMEDIARY ID TYPE CODE VALUE NOT SUPPORTED	
DK4	INTERMEDIARY ID TYPE ENTITY VALUE NOT SUPPORTED	
DK5	INTERMEDIARY ID QUALIFIER VALUE NOT SUPPORTED	
DK6	INTER ID STATE/PROVINCE ADDRESS VALU NOT SUPPORTED	
DK7	INTERMEDIARY ID COUNTRY CODE VALUE NOT SUPPORTED	
DK8	SUBMISSION TYPE CODE NOT USED FOR TRANSACTION CODE	
DK9	LTPAC DISPENSE FREQUENCY NOT USED FOR TRANS CODE	
DL1	LTPAC BILLING METHOD NOT USED FOR TRANSACTION CODE	
DL2	NUMBER LTPAC DISPENS EVENTS NOT USED FOR TRANS CDE	
DL3	MULTI PRSCRPT/SRV ORD GRP RSN CD NOT USED TRANS CD	
DL4	TOTAL PRESCRIB QTY REMAIN NOT USED FOR TRANS CODE	
DL5	PREPARATION ENVIRONMENT TYPE NOT USED TRANS CODE	
DL6	PREP ENVIRONMENT EVENT CODE NOT USED FOR TRANS CDE	
DL7	ORIG MANUF PROD ID QUALIFIER NOT USED TRANS CODE	
DL8	ORIGINAL MANUFACTURER PROD ID NOT USED TRANS CODE	
DL9	LTPAC DISPENSE FREQUENCY NOT USED FOR TRANS CODE	
DM1	LTPAC BILLING METHODOLOGY NOT USED TRANSACTION CDE	
DM2	NUMBER LTPAC DISPENSING EVENTS NOT USED TRANS CODE	
DM3	DO NOT DISPENSE BEFORE DATE NOT USED TRANS CODE	
DM4	SUBROGATION AMOUNT REQUESTED NOT USED TRANS CODE	
DM5	OTHR PAYER ADJUDICATED PGM TYPE NOT USED TRANS CDE	
DM6	OTHER PAYER RECONCILIATION ID NOT USED TRANS CODE	
DM7	INTERMEDIARY SEGMENT NOT USED FOR TRANSACTION CODE	
DM8	LAST KNOWN 4RX SEGMENT NOT USED FOR TRANS CODE	
DM9	N TRANSACTION PAYER ID SEGMENT NOT USED TRANS CODE	
DN	M/I BASIS OF COST DETERMINATION	
DN1	MINIMUM QUANTITY LIMIT NOT MET	
DN2	CLAIM FOR NON-HUMANS NOT COVERED - PLAN/ EXCLUSION	
DQ	M/I USUAL AND CUSTOMARY	
DR	M/I PRESCRIBER LAST NAME	
DT	M/I SPECIAL PACKAGING INDICATOR	
DU	M/I GROSS AMOUNT DUE	
DV	M/I OTHER PAYER AMOUNT PAID	
DX	M/I PATIENT PAID AMOUNT SUBMITTED	

CODE (511-FB)	DESCRIPTION (M/I = Missing/Invalid)	MEVS CODE
DY	M/I DATE OF INJURY	
DZ	M/I CLAIM/REFERENCE ID	
E3	M/I INCENTIVE AMOUNT SUBMITTED	
E8	M/I OTHER PAYER DATE	
EA	M/I ORIGINALLY PRESCRIBED PRODUCT/SERVICE CODE	
EB	M/I ORIGINALLY PRESCRIBED QUANTITY	
EC	M/I COMPOUND INGREDIENT COMPONENT COUNT	
ED	M/I COMPOUND INGREDIENT QUANTITY	
EE	M/I COMPOUND INGREDIENT DRUG COST	
EF	M/I COMPOUND DOSAGE FORM DESCRIPTION CODE	
EG	M/I COMPOUND DISPENSING UNIT FORM INDICATOR	
EJ	M/I ORIGINALLY PRESCRIBED PROD/SERVIC ID QUALIFIER	
EK	M/I SCHEDULED PRESCRIPTION ID NUMBER	725
EM	M/I PRESCRIPTION/SERVIC REFERENCE NUMBER QUALIFIER	
EN	M/I ASSOCIATED PRESCRIPTION/SERVIC REFERENC NUMBER	
EP	M/I ASSOCIATED PRESCRIPTION/SERVICE DATE	
ET	M/I QUANTITY PRESCRIBED	
EU	M/I PRIOR AUTHORIZATION TYPE CODE	
EV	M/I PRIOR AUTHORIZATION NUMBER SUBMITTED	304, 309, 319
EY	M/I PROVIDER ID QUALIFIER	
EZ	M/I PRESCRIBER ID QUALIFIER	
E1	M/I PRODUCT/SERVICE ID QUALIFIER	
E2	M/I ROUTE OF ADMINISTRATION	
E4	M/I REASON FOR SERVICE CODE	
E6	M/I RESULT FOR SERVICE CODE	
E7	M/I QUANTITY DISPENSED	137
FO	M/I PLAN ID	
G1	M/I COMPOUND TYPE	
G2	M/I CMS PART D DEFINED QUALIFIED FACILITY	
G4	PRESCRIBER MUST CONTACT PLAN	
G5	PHARMACIST MUST CONTACT PLAN	
G6	PHARMACY NOT CONTRACTED IN SPECIALTY NETWORK	
G7	PHARMACY NOT CONTRACTED IN HOME INFUSION NETWORK	
G8	PHARMACY NOT CONTRACTED IN LONG TERM CARE NETWORK	
G9	PHARMACY NOT CONTRACTED IN 90 DAY RETAIL NETWORK	
GE	M/I PERCENTAGE SALES TAX AMOUNT SUBMITTED	
H1	M/I MEASUREMENT TIME	
H2	M/I MEASUREMENT DIMENSION	
H3	M/I MEASUREMENT UNIT	
H4	M/I MEASUREMENT VALUE	

CODE (511-FB)	DESCRIPTION (M/I = Missing/Invalid)	MEVS CODE
H6	M/I DUR CO-AGENT ID	
H7	M/I OTHER AMOUNT CLAIMED SUBMITTED COUNT	
H8	M/I OTHER AMOUNT CLAIMED SUBMITTED QUALIFIER	
H9	M/I OTHER AMOUNT CLAIMED SUBMITTED	
HA	M/I FLAT SALES TAX AMOUNT SUBMITTED	
HB	M/I OTHER PAYER AMOUNT PAID COUNT	
HC	M/I OTHER PAYER AMOUNT PAID QUALIFIER	
HD	M/I DISPENSING STATUS	
HE	M/I PERCENTAGE SALES TAX RATE SUBMITTED	
HF	M/I QUANTITY INTENDED TO BE DISPENSED	
HG	M/I DAYS SUPPLY INTENDED TO BE DISPENSED	
HN	M/I PATIENT E-MAIL ADDRESS	
J9	M/I DUR CO-AGENT ID QUALIFIER	
JE	M/I PERCENTAGE SALES TAX BASIS SUBMITTED	
K5	M/I TRANSACTION REFERENCE NUMBER	
M3	HOST PA/MC ERROR	
M4	PRESCRIPT/SVC REFERENCE NUMBER/TIME LIMIT EXCEEDED	
M5	REQUIRES MANUAL REVIEW	
M6	HOST ELIGIBILITY ERROR	
MH	M/I OTHER PAYER PROCESSOR CONTROL NUMBER	
MJ	M/I OTHER PAYER GROUP ID	
MP	OTHER PAYER CARDHOLDER ID NOT COVERED	
MS	MORE THAN 1 CARDHOLDR FOUND-NARROW SEARCH CRITERIA	
MT	M/I PATIENT ASSIGNMENT INDICATOR	
MZ	ERROR OVERFLOW	
N1	NO PATIENT MATCH FOUND	
N3	M/I MEDICAID PAID AMOUNT	
N4	M/I MEDICAID SUBROGATION ICN/TCN	
N5	M/I MEDICAID ID NUMBER	
N6	M/I MEDICAID AGENCY NUMBER	
N7	USE PRIOR AUTH ID PROVIDD DURING TRANSITION PERIOD	
N8	USE PRIOR AUTH ID PROVIDED FOR EMERGENCY SUPPLY	
N9	USE PRIOR AUTH ID PROVIDD FOR LEVEL OF CARE CHANGE	
NN	TRANSACTION REJECTED AT SWITCH OR INTERMEDIARY	
NP	M/I OTHER PAYER PATIENT RESPONSIBILITY QUALIFIER	
NQ	M/I OTHER PAYER PATIENT RESPONSIBILITY AMOUNT	
NR	M/I OTHER PAYER-PATIENT RESPONSIBILITY AMNT COUNT	
NU	M/I OTHER PAYER CARDHOLDER ID	
NV	M/I DELAY REASON CODE	
NX	M/I SUBMISSION CLARIFICATION CODE COUNT	

CODE (511-FB)	DESCRIPTION (M/I = Missing/Invalid)	MEVS CODE
P0	NON-ZERO VALUE REQUIRED FOR VACCINE ADMINISTRATION	
P1	ASSOCIATED PRESCRIP/SVC REFERENCE NUMBER NOT FOUND	
P2	CLINICAL INFORMATION COUNTER OUT OF SEQUENCE	
P3	CMPND INGRED COMPNT COUNT NOT MATCH NUMBER OF REPS	
P4	COB/OTHER PAYMENTS COUNT NOT MATCH NUMBER OF REPS	
P6	DATE OF SERVICE PRIOR TO DATE OF BIRTH	300
P7	DIAG CODE COUNT NOT MATCH NUMBER OF REPETITIONS	
P8	DUR/PPS CODE COUNTER OUT OF SEQUENCE	
P9	FIELD IS NON-REPEATABLE	
PA	PA EXHAUSTED/NOT RENEWABLE	
PB	INVALID TRANSACTION COUNT FOR TRANSACTION CODE	
PC	M/I REQUEST CLAIM SEGMENT	
PD	M/I REQUEST CLINICAL SEGMENT	
PE	M/I COB/OTHER PAYMENTS SEGMENT	
PF	M/I REQUEST COMPOUND SEGMENT	
PH	M/I REQUEST DUR/PPS SEGMENT	
PJ	M/I REQUEST INSURANCE SEGMENT	
PK	M/I REQUEST PATIENT SEGMENT	
PM	M/I REQUEST PHARMACY PROVIDER SEGMENT	
PN	M/I REQUEST PRESCRIBER SEGMENT	
PP	M/I REQUEST PRICING SEGMENT	
PQ	M/I NARRATIVE SEGMENT	
PR	M/I REQUEST PRIOR AUTHORIZATION SEGMENT	
PS	M/I TRANSACTION HEADER SEGMENT	
PT	M/I REQUEST WORKERS COMPENSATION SEGMENT	
PW	EMPLOYER ID NOT COVERED	
PX	OTHER PAYER ID NOT COVERED	
PY	NON-MATCHED UNIT FORM/ROUTE OF ADMINISTRATION	
R0	PROFESS SVC CODE REQUIRD FOR VACCINE INCENTIVE FEE	
R1	OTH AMT CLAIMED COUNT NOT MATCH NUMBER OF REPS	
R2	OTHER PAYER REJECT COUNT NOT MATCH NUMBER OF REPS	
R3	PROC MOD CODE COUNT DOES NOT MATCH NUMBER OF REPS	
R4	PROC MODIFIER CODE INVALID FOR PRODUCT/SERVICE ID	
R5	PRD/SVC ID MUST BE ZERO WHEN PRD/SVC ID QUAL EQ 06	
R7	REPEATING SEGMENT NOT ALLOWED IN SAME TRANSACTION	
R8	SYNTAX ERROR	
R9	VALUE GROSS AMOUNT DUE NOT FOLLOW PRICING FORMULAE	
RA	PA REVERSAL OUT OF ORDER	
RB	MULTIPLE PARTIALS NOT ALLOWED	
RC	DIFFERENT DRUG ENTITY BETWEEN PARTIAL & COMPLETION	

CODE (511-FB)	DESCRIPTION (M/I = Missing/Invalid)	MEVS CODE
RD	MISMTCHED CARDHOLDR/GROUP ID-PARTIAL TO COMPLETION	
RF	IMPROP ORD OF DISPENS STAT CD ON PARTIAL FIL TRANS	
RG	M/I ASSOC PRESCRIPT/SVC REF NUM ON COMPLET TRANS	
RH	M/I ASSOC PRESCRIPT/SVC DATE ON COMPLETION TRANS	
RJ	ASSOCIATED PARTIAL FILL TRANSACTION NOT ON FILE	
RK	PARTIAL FILL TRANSACTION NOT SUPPORTED	
RL	TRANSITIONAL BENEFIT/RESUBMIT CLAIM	
RM	COMPLET TRANS NOT PRMTED WI SAME DOS AS PART TRANS	
RN	PLAN LMITS EXCED ON INTEND PARTIAL FIL FIELD LIMIT	
RP	OUT OF SEQUENCE P REVERSAL ON PARTIAL FILL TRANS	
RR	M/I PATIENT ID COUNT	
RS	M/I ASSOCIATED PRESCRIPT/SVC DATE ON PARTIAL TRANS	
RT	M/I ASSCTED PRESCRIPT/SVC REF NUM ON PARTIAL TRANS	
RU	MANDTRY DES MUST OCCUR BEFORE OPTIONAL DES SEGMENT	
S0	ACCUM MONTH COUNT NOT MATCH NUMBER OF REPETITIONS	
S1	M/I ACCUMULATOR YEAR	
S2	M/I TRANSACTION IDENTIFIER	
S3	M/I ACCUMULATED PATIENT TRUE OUT OF POCKET AMOUNT	
S5	M/I DATETIME	
S6	M/I ACCUMULATOR MONTH	
S7	M/I ACCUMULATOR MONTH COUNT	
S8	NON-MATCHED TRANSACTION IDENTIFIER	
S9	M/I FINANCIAL INFO REPORTING TRANS HEADER SEGMENT	
SE	M/I PROCEDURE MODIFIER CODE COUNT	
SF	OTHR PAYER AMT PAID COUNT NOT MATCH NUMBER OF REPS	
SG	SCC COUNT DOES NOT MATCH NUMBER OF REPETITIONS	
SH	OTHR PAYER-PAT RESPONS AMT CNT NOT MATCH NUM REPS	
SW	ACCUM PATNT OUT OF POCKET MUST BE EQUAL OR GT ZERO	
T0	ACCUM MONTH CNT EXCEEDS NUM OF OCCURRENC SUPPORTED	
T1	REQUEST FINANCI SEG RQRD FOR FINANCIAL INFO REPORT	
T2	M/I REQUEST REFERENCE SEGMENT	
T3	OUT OF ORDER DATETIME	
T4	DUPLICATE DATETIME	
TH	PATIENT ID COUNT NOT MATCH NUMBER OF REPETITIONS	
TN	EMERGENCY SUPPLY/RESUBMIT CLAIM	
TO	DOSAGE EXCEEDS PRODUCT LABELING LIMIT	
TP	LEVEL OF CARE CHANGE/RESUBMIT CLAIM	
TR	M/I BILLING ENTITY TYPE INDICATOR	
TS	M/I PAY TO QUALIFIER	
TT	M/I PAY TO ID	

CODE (511-FB)	DESCRIPTION (M/I = Missing/Invalid)	MEVS CODE
TU	M/I PAY TO NAME	
TW	M/I PAY TO CITY ADDRESS	
TX	M/I PAY TO STATE/ PROVINCE ADDRESS	
TY	M/I PAY TO ZIP/POSTAL ZONE	
TZ	M/I GENERIC EQUIVALENT PRODUCT ID QUALIFIER	
U7	M/I PHARMACY SERVICE TYPE	
UA	M/I GENERIC EQUIVALENT PRODUCT ID	
UU	DAW 0 CANNOT BE ON MLTI-SRC DRUG WI AVAIL GENERICS	
UZ	OTHR PAYR CVRG TYP REQRD ON REVERSL RESUB REVERSL	
VA	PAY TO QUALIFIER VALUE NOT SUPPORTED	
VB	GENERIC EQUIVALENT PROD ID QUALIFIER NOT SUPPORTED	
VC	PHARMACY SERVICE TYPE VALUE NOT SUPPORTED	
VD	ELIGIBILITY SEARCH TIME FRAME EXCEEDED	
VE	M/I DIAGNOSIS CODE COUNT	
W9	ACCUM GROS CVRD DRUG COST MUST BE EQUAL OR GT ZERO	
WE	M/I DIAGNOSIS CODE QUALIFIER	
X0	M/I ASSOCIATED PRESCRIPTION/SERVICE FILL NUMBER	
X1	ACCUMUL PATIENT TRUE OUT OF POCKET EXCEEDS MAXIMUM	
X2	ACCUMULATD GROSS COVERED DRUG COST EXCEEDS MAXIMUM	
X3	OUT OF ORDER ACCUMULATOR MONTHS	
X4	ACCUMULATOR YEAR IS NOT WITHIN ATBT TIMEFRAME	
X5	M/I FINANCIAL INFO REPORT REQUEST INSURANCE SGMNT	
X6	M/I REQUEST FINANCIAL SEGMENT	
X7	FINACIL RPT REQ INSUR SEG RQRD FOR FINACIL RPTING	
X8	PROC MOD CDE COUNT EXCEEDS NUM OCCURRENCE SUPPORTD	
X9	DIAG CODE CNT EXCEEDS NUM OF OCCURRENCES SUPPORTED	
XE	M/I CLINICAL INFORMATION COUNTER	
XZ	M/I ASSOCIATED PRSCRIP/SVICE REF NUMBER QUALIFIER	
Y0	M/I PURCHASER LAST NAME	
Y1	M/I PURCHASER STREET ADDRESS	
Y2	M/I PURCHASER CITY ADDRESS	
Y3	M/I PURCHASER STATE/PROVINCE CODE	
Y4	M/I PURCHASER ZIP/POSTAL CODE	
Y5	M/I PURCHASER COUNTRY CODE	
Y6	M/I TIME OF SERVICE	
Y7	M/I ASSOCIATED PRESCRPT/SERVICE PROV ID QUALIFIER	
Y8	M/I ASSOCIATED PRESCRIPTION/SERVICE PROVIDER ID	
Y9	M/I SELLER ID	
YA	CMPD INGRED MOD CODE COUNT EXCEEDS OCCURNCES SPRTD	
YB	OTH AMT CLAIMED SUBMIT CNT EXCEEDS NUM OCCUR SPRTD	

CODE (511-FB)	DESCRIPTION (M/I = Missing/Invalid)	MEVS CODE
YC	OTH PAYER REJECT CNT EXCEEDS NUM OCCURRENC SPORTE	
YD	OTH PAYR-PAT RESPNS AMT CNT EXCEDS NUM OCCUR SPRTD	
YE	SCC CNT EXCEEDS NUMBER OF OCCURRENCES SUPPORTED	
YF	QUESTION NUMBER/LETTER CNT EXCEEDS NUM OCCUR SPRTD	
YH	CLIN INFO CTR EXCEEDS NUM OF OCCURRENCES SUPPORTED	
YJ	MEDICAID AGENCY NUMBER NOT SUPPORTED	
YK	M/I SERVICE PROVIDER NAME	
YM	M/I SERVICE PROVIDER STREET ADDRESS	
YN	M/I SERVICE PROVIDER CITY ADDRESS	
YP	M/I SERVICE PROVIDER STATE/PROVINCE CODE ADDRESS	
YQ	M/I SERVICE PROVIDER ZIP/POSTAL CODE	
YR	M/I PATIENT ID ASSOCIATED STATE/PROVINCE ADDRESS	
YS	M/I PURCHASER RELATIONSHIP CODE	
YT	M/I SELLER INITIALS	
YU	M/I PURCHASER ID QUALIFIER	
YV	M/I PURCHASER ID	
YW	M/I PURCHASER ID ASSOCIATED STATE/PROVINCE CODE	
YX	M/I PURCHASER DATE OF BIRTH	
YY	M/I PURCHASER GENDER CODE	
YZ	M/I PURCHASER FIRST NAME	
Z0	PURCHASER COUNTRY CODE NOT SUPPORTED FOR PROCESSOR	
Z1	PRESCRIBER ALT ID QUALIFIER VALUE NOT SUPPORTED	
Z2	M/I PURCHASER SEGMENT	
Z3	PURCH SEG PRESNT ON NON-CNTRLD SUBSTANC RPT TRANS	
Z4	PURCH SEG REQRD ON CNTRLD SUBSTANC RPT TRANS	
Z5	M/I SERVICE PROVIDER SEGMENT	
Z6	SRV PROV SEG PRSNT ON NON-CNTRLD SUBSTNC RPT TRANS	
Z7	SVC PROV SEG REQRD ON CNTRLD SUBSTANC RPT TRANS	
Z8	PURCHASER RELATIONSHIP CODE VALUE NOT SUPPORTED	
Z9	PRESCRIBER ALTERNATE ID NOT COVERED	
ZB	M/I SELLER ID QUALIFIER	
ZC	ASSOC PRS/SVC PROV ID QUAL NOT FOR PROCESSOR/PAYER	
ZD	ASSOC PRS/SVC REFERENCE NUMBER QUAL NOT SUPPORTED	
ZE	M/I MEASUREMENT DATE	
ZF	M/I SALES TRANSACTION ID	
ZK	M/I PRESCRIBER ID ASSOCIATD STATE/PROVINCE ADDRESS	
ZM	M/I PRESCRIBER ALTERNATE ID QUALIFIER	
ZN	PURCH ID QUALIFER NOT SUPPORTD FOR PROCESSOR/PAYER	
ZP	M/I PRESCRIBER ALTERNATE ID	
ZQ	M/I PRESCRIB ALT ID ASSOCIAT STATE/PROVINCE ADDRESS	

CODE (511-FB)	DESCRIPTION (M/I = Missing/Invalid)	MEVS CODE
ZS	M/I REPORTED ADJUDICATED PROGRAM TYPE	
ZT	M/I RELEASED DATE	
ZU	M/I RELEASED TIME	
ZV	REPORT ADJUDICATED PROGRAMTYPE VALUE NOT SUPPORTED	
ZW	M/I COMPOUND PREPARATION TIME	
ZX	M/I CMS PART D CONTRACT ID	
ZY	M/I MEDICARE PART D PLAN BENEFIT PACKAGE (PBP)	
ZZ	CARDHOLDER ID INACTIVE NEW CARDHOLDER ID ON FILE	

Up to twenty (5 per line) NCPDP reject codes can appear in the rejected response. If a code has a comparable MEVS reject code that code will also be returned in the response.

16.0 INSURANCE COVERAGE CODES - TABLE 11 (Rev. 5/11)

The message will only return coverage codes for Medicaid Managed Care Plans.

These codes identify which services are covered by the member's managed care plan.

<u>COVERAGE CODES</u>	<u>DESCRIPTION</u>	<u>EXPLANATION</u>
A	Inpatient Hospital	All inpatient services are covered except psychiatric care.
B	Physician In-Office	Services provided in the physician's office are generally covered.
C	Emergency Room	Self-Explanatory.
D	Clinic	Both hospital based and freestanding clinic services are covered.
E	Psychiatric Inpatient	Self-Explanatory.
F	Psychiatric Outpatient	Self-Explanatory.
G	Physician In-Hospital	Physician services provided in a hospital or nursing home are covered.
H	Drugs No Card	Drug coverage is available but a drug card is not needed.
I	Lab/X-Ray	Laboratory and x-ray services are covered.
J	Dental	Self Explanatory. Note: Orthodontia is a carved out service, so all COVERED orthodontic care is paid on a fee-for-service basis, even for members enrolled in a plan that otherwise covers dental services.
L	Nursing Home	Some nursing home coverage is available. You must bill until benefits are exhausted.
M	Drugs Major Medical	Drug coverage is provided as part of a major medical policy.
N	All Physician Services	Physician services, without regard to where they were provided, are covered.

<u>COVERAGE CODES</u>	<u>DESCRIPTION</u>	<u>EXPLANATION</u>
O	Drugs	Self-Explanatory.
P	Home Health	Some home health benefits are provided. Continue to bill until benefits are exhausted.
Q	Psychiatric Services	All psychiatric services, inpatient and outpatient, are covered.
R	ER and Clinic	Self-Explanatory.
S	Major Medical	The following services are covered: physician, clinic, emergency room, inpatient, laboratory, referred ambulatory, transportation and durable medical equipment.
T	Transportation	Medically necessary transportation is covered.
U	Coverage to Complement Medicare	All services paid by Medicare which require a coinsurance or deductible payment should be billed to the insurance carrier prior to billing Medicaid.
V	Substance Abuse Svcs.	All substance abuse services, regardless of where they are provided are covered.
W	Substance Abuse Outpatient	Self-Explanatory.
X	Substance Abuse Inpatient	Self-Explanatory.
Y	Durable Medical Equipment	Self-Explanatory.
Z	Optical	Self-Explanatory.
All	All of the above	All services listed in coverage codes A-Z are covered by the member's insurance carrier.

17.0 EXCEPTION CODES - TABLE 12 (Rev. 12/22)

Exception Codes are two-digit codes that identify a member's program exceptions or restrictions.

CODE	DESCRIPTION
Code 23	This code identifies a member who is enrolled in the OMH Home and Community Based Services (HCBS) Waiver for Seriously Emotionally Disturbed (SED) children. This member is exempt from Co-pay requirements. <i>This code will be inactivated to prevent use after January 1, 2019.</i>
Code 24	This code identifies a member who is enrolled in a Chronic Illness Demonstration Project (CIDP) program. The member's participation in a CIDP does not affect eligibility for other Medicaid services. This member is not exempt from co-payment requirements.
Code 30	This code identifies a Medicaid member who is enrolled in the Long Term Home Health Care Program Waiver also known as the Lombardi Program/nursing home without walls. The member is authorized to receive LTHHCP services from an enrolled LTHHCP provider. This member is not exempt from co-payment requirements.
Code 35	This member is enrolled in a Comprehensive Medicaid Case Management (CMCM) program. The member's participation in CMCM does not affect eligibility for other Medicaid services. This member is exempt from Co-payment requirements.
Code 38	The member is resident in an ICF-DD facility. You should contact the ICF-DD to find out if the service is included in their per diem rate. If it is not, the claim can be submitted to the NYS Medicaid Program. This member is exempt from Co-payment requirements and may be eligible for some fee-for-service Medicaid coverage.
Code 39	This code identifies a member in the Aid Continuing program. This member is exempt from Co-payment requirements.
Code 44	This code identifies a Medicaid member who is enrolled in OPWDD's Home and Community Based Services (HCBS) Waiver and is authorized to receive Non-Intensive At Home Residential Habilitation services. This member is exempt from Co-payment requirements.
Code 45	This code identifies a Medicaid member who is enrolled in OPWDD's Home and Community Based Services (HCBS) Waiver and is authorized to receive Intensive At Home Residential Habilitation services. This member is exempt from Co-payment requirements.
Code 46	This code identifies a Medicaid member who is enrolled in OPWDD's Home and Community Based Services (HCBS) Waiver and is authorized to receive services. This member is exempt from Co-payment requirements.
Code 47	This code identifies a Medicaid member who is enrolled in OPWDD's Home and Community Based Service (HCBS) Waiver and resides in a <i>supervised</i> Community Residence. This member is exempt from Co-payment requirements.
Code 48	This code identifies a Medicaid member who is enrolled in OPWDD's Home and Community Based Service (HCBS) Waiver and resides in a <i>supportive</i> Community Residence (CR) or a <i>supportive</i> Individual Residential Alternative (IRA). This member is exempt from Co-payment requirements.

CODE	DESCRIPTION
Code 49	<p>This code identifies a Medicaid member who is enrolled in OPWDD's Home and Community Based Services (HCBS) Waiver, resides in a <i>supervised</i> Individual Residential Alternative (IRA) and is authorized to receive IRA residential habilitation services.</p> <p>This member is exempt from Co-payment requirements.</p>
Code 50	<p>This member has Connect services, plus is eligible for the service package available to all members with Perinatal Family. This member is exempt from Co-payment requirements.</p>
Code 51	<p>This member has Connect services, plus is eligible for the services described in the Eligibility Response associated with the member. This member is exempt from Co-payment requirements.</p>
Code 54	<p>This code designates a member whose outpatient Medicaid coverage is limited to Home Health and Personal Care Services benefits.</p> <p>This member is not exempt from Co-payment requirements.</p>
Code 60	<p>This code identifies a member who is receiving Home and Community Based Services (HCBS) as part of the Nursing Home Transition and Diversion Waiver program.</p> <p>This member is exempt from Co-payment requirements.</p>
Code 62	<p>This code identifies a member in the Care At Home I program.</p> <p>This member is exempt from completion of HARRI (the Long Term Home Health Care Assessment Tool) Co-payment requirements.</p> <p><i>This code will be inactivated to prevent use after January 1, 2019.</i></p>
Code 63	<p>This code identifies a member in the Care At Home II program.</p> <p>This member is exempt from completion of HARRI (the Long Term Home Health Care Assessment Tool), Co-payment requirements.</p> <p><i>This code will be inactivated to prevent use after January 1, 2019.</i></p>
Code 64	<p>This code identifies a member in the Care At Home III program.</p> <p>This member is exempt from completion of HARRI (the Long Term Home Health Care Assessment Tool) Co-payment requirements.</p> <p><i>This code will be inactivated to prevent use after January 1, 2019.</i></p>
Code 65	<p>This code identifies a member in the Care At Home IV program.</p> <p>This member is exempt from completion of HARRI (the Long Term Home Health Care Assessment Tool) Co-payment requirements.</p> <p><i>This code will be inactivated to prevent use after January 1, 2019.</i></p>
Code 66	<p>This code identifies a member in the Care At Home V program.</p> <p>This member is exempt from completion of HARRI (the Long Term Home Health Care Assessment Tool) Co-payment requirements.</p>
Code 67	<p>This code identifies a member in the Care At Home VI program.</p> <p>This member is exempt from completion of HARRI (the Long Term Home Health Care Assessment Tool) Co-payment requirements.</p>
Code 68	<p>This code identifies a member in the Care At Home VII program.</p> <p>This member is exempt from completion of HARRI (the Long Term Home Health Care Assessment Tool), Co-payment requirements.</p>
Code 69	<p>This code identifies a member in the Care At Home VIII program.</p> <p>This member is exempt from completion of HARRI (the Long Term Home Health Care Assessment Tool) Co-payment requirements.</p>
Code 70	<p>This code identifies a member in the Care At Home IX program.</p>

CODE	DESCRIPTION
	This member is exempt from completion of HARRI (the Long Term Home Health Care Assessment Tool) Co-payment requirements.
Code 71	This code identifies a member in the Care At Home X program. This member is exempt from completion of HARRI (the Long Term Home Health Care Assessment Tool), Co-payment requirements.
Code 72	This Restriction/Exception code identifies Medicaid Members under the age of 21 who are participants in the Bridges to Health Waiver for the Seriously Emotionally Disturbed (B2H/SED). This waiver is for children who are initially in foster care and who can remain in the waiver once discharged, if otherwise eligible. This member is exempt from Co-payment requirements. <i>This code will be inactivated to prevent use after January 1, 2019.</i>
Code 73	This Restriction/Exception code identifies Medicaid Members under the age of 21 who are participants in the Bridges to Health Waiver for Developmentally Disabled (B2H). This waiver is for children who are initially in foster care and who can remain in the waiver once discharged, if otherwise eligible. This member is exempt from Co-payment requirements. <i>This code will be inactivated to prevent use after January 1, 2019.</i>
Code 74	This Restriction/Exception code identifies Medicaid Members under the age of 21 who are participants in the Bridges to Health Waiver for the Medically Fragile (B2H/MedF). This waiver is for children who are initially in foster care but who can remain in the waiver after discharge, if otherwise eligible. This member is exempt from Co-payment requirements. <i>This code will be inactivated to prevent use after January 1, 2019.</i>
Code 75	This code identifies a participant of the Partnership program who has Dollar for Dollar Asset Protection. The member may have long term care insurance benefits available for certain long term care services. You should contact the insurance to find out if the service is covered. If it is not, the claim can be submitted to the NYS Medicaid Program. Participation in the Partnership does not affect eligibility for other Medicaid services. This member is not exempt from Co-payment requirements.
Code 76	This code identifies a participant of the Partnership program who has Total Asset Protection. The member may have long term care insurance benefits available for certain long term care services. You should contact the insurance to find out if the service is covered. If it is not, the claim can be submitted to the NYS Medicaid Program. Participation in the Partnership does not affect eligibility for other Medicaid services. This member is not exempt from Co-payment requirements.
Code 77	This code identifies a member that may have long term care insurance benefits available for certain long term care services. You should contact the insurance to find out if the service is covered. If it is not, the claim can be submitted to the NYS Medicaid Program. This member is not exempt from Co-payment requirements.
Code 81	This code identifies a member in a Home and Community Based Services (HCBS) Waiver Program for Traumatic Brain Injury (TBI). This member is exempt from Co-payment requirements.
Code 82	This code identifies a member in the Recipient Restriction Program who is enrolled in a managed care plan. The member is restricted to a plan network provider who is not a FFS MMIS provider. Inquiries concerning service to recipients with Code 82 should be directed to the managed care plan. This member is not exempt from Co-payment requirements.

CODE	DESCRIPTION
Code 83	<p>This code identifies a member who has been mandated by the local social services district to receive certain alcohol and substance abuse services as a condition of eligibility for public assistance or Medicaid as a result of welfare reform requirements.</p> <p>For managed care enrollees, the presence of this code allows certain substance abuse services to be paid on a fee for service basis. The code may be used to trigger prior approval requirements.</p>
Code 84	<p>This code identifies a Medicaid member who is enrolled in the OMH's Personalized Recovery Oriented Services (PROS) program and is authorized to receive Community Rehabilitation and Support (CRS) With Clinic Treatment.</p> <p>Other base and clinical PROS programs, OMH clinic, CDT, IPRT, PMHP, and ACT intensive claims will be denied payment.</p> <p>This member is exempt from Co-payment requirements.</p>
Code 85	<p>This code identifies a Medicaid member who is enrolled in the OMH's Personalized Recovery Oriented Services (PROS) program and is authorized to receive Community Rehabilitation and Support (CRS) Without Clinic Treatment.</p> <p>Other base PROS programs, OMH CDT, IPRT, and ACT intensive claims will be denied payment.</p> <p>This member is exempt from Co-payment requirements.</p>
Code 86	<p>This code identifies a Medicaid member who is enrolled in the OMH's Personalized Recovery Oriented Services (PROS) program and is authorized to receive Intensive Rehabilitation (IR) or Ongoing Rehabilitation and Support (ORS).</p> <p>Other PROS providers will be denied payment for these services. OMH IPRT claims will be denied payment.</p> <p>This member is exempt from Co-payment requirements.</p>
Code 89	<p>This code identifies a Medicaid member who is enrolled in the Money Follows The Person (MFP) Rebalancing Demonstration program. The member's participation in MFP does not affect eligibility for other Medicaid services.</p>
Code 95	<p>This code identifies members with a mental retardation or developmental disability diagnosis who are eligible to be billed under an enhanced APG (Ambulatory Patient Groups) base rate for clinical services. It will allow for payment of the following rates codes:</p> <p style="padding-left: 40px;">1425 - MR/DD/TBI APG Base Rate (Episode) 1435 - MR/DD/TBI APG Base Rate (Visit) 1489 - MR/DD/TBI APG Base Rate (Episode) 1501 - MR/DD/TBI APG Base Rate (Visit)</p> <p>This member is not exempt from Co-payment requirements. This member is exempt for annual visit caps for OT, PT, and SLP services delivered by clinics and independent practitioners. This member is eligible for the OPWDD Independent Practitioner Services for Individuals with Developmental Disabilities (IPSIDD) enhanced reimbursement.</p>
Code A1	<p>Client in outreach or enrolled with a Care Management Agency, eMedNY will provide Provider NPI or Provider MMIS ID and Name.</p> <p>This member is exempt from Co-payment requirements.</p>
Code A2	<p>Client in outreach or enrolled with a Health Home, eMedNY will provide Provider NPI or MMIS ID and Name.</p> <p>This member is exempt from Co-payment requirements.</p>
Code AL	<p>This code identifies a member who resides in an Assisted Living Program residence. The following services are included in the ALP's Medicaid per diem rate and cannot be billed to the Medicaid Program:</p> <ol style="list-style-type: none"> 1. Adult day health care provided in a program approved by the Department of Health; 2. Home health aide services;

CODE	DESCRIPTION
	3. Medical supplies and equipment NOT requiring prior approval (underlined procedure codes in the DME and Pharmacy provider manuals are prior approved); 4. Nursing services; 5. Personal care services; 6. Personal emergency response services; and 7. Physical therapy, speech therapy, and occupational therapy.
Code B7	Non-EP Aliessa Immigrant
Code C1	Copay Exempt (Hospice) - Exempt individuals receiving Hospice Care from copay by recognizing Hospice Rate Codes.
Code C2	The Client has Medicare/Medicaid Hospice elected. Medicaid pays the Hospice organization an all-inclusive daily rate. The following Medicaid services/programs are not allowed in combination with the Hospice benefit: <ul style="list-style-type: none"> • Private Duty Nursing • Long Term Home Health Care Program/Lombardi Program • Certified Home Health Agency Services • Adult Day Health Care Services These services should be covered by the Hospice provider under the all-inclusive Hospice rate. This member is exempt from Co-payment requirements.
Code CF	Clients who qualify for Community First Choice Options services who are not enrolled in OPWDD. This code identifies the person who has met the eligibility requirements for receiving these services
Code CH	This code identifies a Medicaid member who is enrolled in the Care Restructuring Enhancement Program (CREP), HCBS – Home and Community Based Services. This member is not exempt from Co-payment requirements.
Code CM	This code identifies a Medicaid member who is enrolled in the Care Restructuring Enhancement Program (CREP), MLTC- Managed Long Term Care. This member is not exempt from Co-payment requirements.
Code CO	Clients who qualify for Community First Choice Options services who are enrolled in OPWDD. This code identifies the person who has met the eligibility requirements for receiving these services.
Code G1	(Transgender Individual Male to Female) Individual has or is in the process of transitioning from a Male to a Female.
Code G2	(Transgender Individual Female to Male) Individual has or is in the process of transitioning from a Female to a Male.
Code H1	HARP enrolled without HCBS eligibility- This code identifies the person as enrolled in a HARP (Health and Recovery Plan). It also indicates that the person is NOT eligible for the special HARP wrap-around Home and Community Based Services (HCBS).
Code H2	HARP enrolled with Tier 1 HCBS eligibility- This code identifies the person as enrolled in a HARP. It also indicates that the person has been assessed and determined to be eligible for Tier 1 HCBS services (peer supports, employment supports, education supports).
Code H3	HARP enrolled with Tier 2 HCBS eligibility- This code identifies the person as enrolled in a HARP. It also indicates that the person has been assessed and determined to be eligible for Tier 2 HCBS services (which includes all Tier 1 services listed under H2, plus psychosocial rehab, community psychiatric supports and treatment, etc.).
Code H4	HIV SNP HARP – eligible without HCBS eligibility- This code identifies the person as HARP eligible, but with enrollment in an HIV SNP. They have NOT been determined to be eligible for the special HCBS benefit package associated with some HARP eligibles.
Code H5	HIV SNP HARP – eligible with Tier 1 HCBS eligibility- This code identifies the person as HARP eligible, but with enrollment in an HIV SNP. It also indicates they have been assessed and

CODE	DESCRIPTION
	determined to be eligible for the Tier 1 HCBS services, which will be administered by their HIV SNP.
Code H6	HIV SNP HARP – eligible with Tier 2 HCBS eligibility- This code identifies the person as HARP eligible, but with enrollment in an HIV SNP. It also indicates they have been assessed and determined to be eligible for the Tier 2 HCBS services, which will be administered by their HIV SNP.
Code H7	Opted Out of HARP- This indicates a person was HARP- eligible but who, when given the option to enroll, declined enrollment.
Code H8	HARP ELIG COMMUNITY REFERRAL - This code indicates the person has been identified by OMH, OASIS, DOH, or another designated entity as potentially HARP eligible. An assessment will need to be done on the person and if the results of the assessment show the person to be HARP eligible, they will be given the choice of joining a HARP (and given code H1, with the potential for H2 or H3 based on the results of a detailed assessment). If this person is already in an HIV SNP they can remain in the HIV SNP. They will receive code H4 and, based on the results of a more in depth assessment, possibly qualify for HCBS services under codes H5 or H6.
Code H9	HARP ELIG STATE IDENTIFIED - This person has been determined to be “categorically eligible” for a HARP. They will be given the option of moving to a HARP (where they will be given code H1, with the potential for H2 or H3 based on the results of a detailed assessment). If this person were already in an HIV SNP they would not have been given code H9, but rather code H4. They can choose to remain in the HIV SNP or move to a HARP. If they remain in the HIV SNP they could potentially, based on the results of a more in depth assessment, qualify for HCBS services under codes H5 or H6.
Code I1	This code identifies a Medicaid member who is enrolled in OPWDD MC CLASS 1. This member is not exempt from co-payment requirements.
Code I2	This code identifies a Medicaid member who is enrolled in OPWDD MC CLASS 2. This member is not exempt from co-payment requirements.
Code I3	This code identifies a Medicaid member who is enrolled in OPWDD MC CLASS 3. This member is not exempt from co-payment requirements.
Code I4	This code identifies a Medicaid member who is enrolled in OPWDD MC WILLOWBROOK. The member is not exempt from Co-payment requirements.
Code I5	This code identifies a Medicaid member who is enrolled in an OPWDD Care Coordination Organization/Health Home (CCO/HH) at level one acuity. The member is exempt from Co-pay requirements.
Code I6	This code identifies a Medicaid member who is enrolled in an OPWDD Care Coordination Organization/Health Home (CCO/HH) at level two acuity. The member is exempt from Co-pay requirements.
Code I7	This code identifies a Medicaid member who is enrolled in an OPWDD Care Coordination Organization/Health Home (CCO/HH) at level three acuity. The member is exempt from Co-pay requirements.
Code I8	This code identifies a Medicaid member who is enrolled in an OPWDD Care Coordination Organization/Health Home (CCO/HH) at level four acuity. The member is exempt from Co-pay requirements.
Code I9	This code identifies a Medicaid member who is eligible for OPWDD CCO/HH services, but has instead opted for basic HCBS plan support in lieu of full health home services. Although not a health home service itself, this option is also delivered by CCO/HH provider agencies. The member is exempt from Co-pay requirements

CODE	DESCRIPTION
Code K1	This code identifies a consumer who is under 21 and meets a Level of Care HCBS Eligibility Determination. Consumer is exempt from Co-payment requirements.
Code K2	This code identifies a consumer who is under 21 and meets a Level of Need HCBS Eligibility Determination. Consumer is exempt from Utilization Threshold and Co-payment requirements.
Code K3	This code identifies a consumer who is under age 21 and has a serious emotional disturbance as defined by the CANS-NY. Consumer is exempt from Co-payment requirements.
Code K4	This code identifies a consumer who is under age 21 and is medically fragile as defined by the CANS-NY. Consumer is exempt from Co-payment requirements.
Code K5	This code identifies a consumer who is under age 21 and a child in foster care with developmental disability as defined by the OPWDD. Consumer is exempt from Co-payment requirements.
Code K6	This code identifies a consumer who is under age 21 and has co-occurring developmental disability and medical fragility as defined by the CANS-NY. Consumer is exempt from Co-payment requirements.
Code K7	This code identifies a consumer who is under age 21 and has experienced physical, emotional, or sexual abuse or neglect, or maltreatment defined by the CANS-NY. Consumer is exempt from Co-payment requirements.
Code K9	This code identifies a consumer who is under age 21 and has any foster care placement, either through a voluntary foster care agency or the local district of social services. Consumer is exempt from Co-payment requirements.
Code KK	This code identifies a consumer who is under age 18 and is Medicaid-eligible using Family of One budgeting. Consumer is exempt from Co-payment requirements.
Code M1	This code identifies a Medicaid member who is eligible in a MAGI (Modified Adjusted Gross Income) category and is receiving services only available through LDSS. This member is excluded from transition to NYSOH (NY State of Health).
Code N1	This code identifies a regular Nursing Home bed type of a Medicaid managed care enrollee to the managed care health plan. Entry of this code will allow Medicaid managed care plans to receive an adjusted premium due to long term Nursing Home placement.
Code N2	This code identifies an AIDS Nursing Home bed type of a Medicaid managed care enrollee to the managed care health plan. Entry of this code will allow Medicaid managed care plans to receive an adjusted premium due to long term Nursing Home placement.
Code N3	This code identifies a Neuro-Behavioral Nursing Home bed type of a Medicaid managed care enrollee to the managed care health plan. Entry of this code will allow Medicaid managed care plans to receive an adjusted premium due to Nursing Home placement.
Code N4	This code identifies a Traumatic Brain Injury (TBI) Nursing Home bed type of a Medicaid managed care enrollee to the managed care health plan. Entry of this code will allow Medicaid managed care plans to receive an adjusted premium due to long term Nursing Home placement.
Code N5	This code identifies a Ventilator Dependent Nursing Home bed type of a Medicaid managed care enrollee to the managed care health plan. Entry of this code will allow Medicaid managed care plans to receive an adjusted premium due to long term Nursing Home placement.
Code N6	This code identifies a MLTC partial cap/MAP enrollee who has been permanently placed in a nursing facility.

CODE	DESCRIPTION
Code N7	This code identifies a fee for service consumer who has been determined eligible for nursing facility services and is required to enroll in a managed care health plan. Consumer will need to enroll in a managed care health plan within 60 days or will be auto assigned. This code triggers Enrollment Broker outreach/enrollment activities.
Code N8	This code is for local districts to enter a transfer penalty period for consumers who have been permanently placed in a nursing facility but are not eligible for Medicaid payment nursing facility services due to a transfer penalty.
Code N9	This code identifies fee-for-service consumers and managed care plan enrollees who are pending nursing home eligibility determination. This member is not exempt from Co-payment requirements.
Code NH	This code identifies a member in a Nursing Home facility. The majority of the member's care is provided by the Nursing Home and is included in their Medicaid per diem rate. If you provide a service to a NH member, you must contact the Nursing Home to find out if the service is included in their rate. If it is not, the claim can be submitted to the NYS Medicaid Program.
Code PL	(Upstate) Pre-release from NYS Department of Corrections and Community Supervision (NYS DOCCS) facility, Managed Care Ineligible.
Code PR	(Downstate) Pre-release from NYS Department of Corrections and Community Supervision (NYS DOCCS) facility, Managed Care Ineligible.
Code S1	Surplus Client not Eligible for Medicaid Managed Care or Medicaid Advantage Enrollment.

18.0 COUNTY/DISTRICT CODES - TABLE 13 (Rev. 05/11)

The County/District, two-digit codes are used to identify the member's county of fiscal responsibility.

01 Albany	31 Onondaga
02 Allegany	32 Ontario
03 Broome	33 Orange
04 Cattaraugus	34 Orleans
05 Cayuga	35 Oswego
06 Chautauqua	36 Otsego
07 Chemung	37 Putnam
08 Chenango	38 Rensselaer
09 Clinton	39 Rockland
10 Columbia	40 St. Lawrence
11 Cortland	41 Saratoga
12 Delaware	42 Schenectady
13 Dutchess	43 Schoharie
14 Erie	44 Schuyler
15 Essex	45 Seneca
16 Franklin	46 Steuben
17 Fulton	47 Suffolk
18 Genesee	48 Sullivan
19 Greene	49 Tioga
20 Hamilton	50 Tompkins
21 Herkimer	51 Ulster
22 Jefferson	52 Warren
23 Lewis	53 Washington
24 Livingston	54 Wayne
25 Madison	55 Westchester
26 Monroe	56 Wyoming
27 Montgomery	57 Yates
28 Nassau	66 New York City
29 Niagara	97 OMH Administered
30 Oneida	98 OMR/DD Administered
	99 Oxford Home

19.0 NEW YORK CITY OFFICE CODES - TABLE 14 (Rev. 01/15)

For members who have coverage through the NY Health Benefit Exchange, the three-digit Office Code 'H78' will be returned. The phone number for inquiries pertaining to eligibility issues for members enrolled through the NY Health Benefit Exchange is 855-355-5777.

The office codes and descriptions listed below are only returned for **County Code 66** members. \

Public Assistance**Manhattan**

013 Waverly
019 Yorkville
023 East End
024 Amsterdam
026 St. Nicolas
028 Hamilton
032 East Harlem
035 Dyckman
037 Roosevelt

Bronx

038 Rider
039 Boulevard
040 Melrose
041 Tremont
043 Kingsbridge
044 Fordham
045 Concourse
046 Crotona
047 Soundview
048 Bergen
049 Willis

Queens

051 Queensboro
052 Office of Treatment Monitoring
053 Queens
054 Jamaica
079 Rockaway

Brooklyn

061 Fulton
062 Clinton
063 Wyckoff
064 Dekalb
066 Bushwick
067 Linden
068 Prospect
070 Bay Ridge
071 Nevins
072 Livingston
073 Brownsville
078 Euclid
080 Fort Greene
084 Williamsburg

Staten Island

099 Richmond

Medical Assistance

500-593 34th Street Manhattan

Special Services for Children (SSC)

DOP Division of Placement
OPA Office of Placement and Accountability

Field Offices

071 Bronx
072 Brooklyn
073 Manhattan
074 Queens
075 Staten Island

Office of Direct Child Care Services

801 Brooklyn
802 Jamaica
806 Manhattan
810 Division of Group Homes
823 Division of Group Residence
826 Diagnostic Reception Centers

PCP Plan Codes

Click here to view the [Prepaid Capitation Plan Codes](#).